

TRUMPF  
Automation

Everything  
under control.



# Well-equipped for the future.

What will tomorrow's manufacturing look like? Globalization, technological progress and economic fluctuations will directly impact your company. With the help of intelligent systems, you can create the basis for a successful future today.

## MORE FLEXIBLY

To compensate for economic fluctuations, you should be able to deploy your resources flexibly. Modular automation concepts from TRUMPF will help you.



Closer to  
the market

---

## MORE QUICKLY

Product life cycles are changing as international competitive pressures rise. With automation, you can respond more quickly and manufacture with greater resource efficiency.



Less is more

---

## MORE EFFICIENTLY

Increasingly broader product ranges and smaller batch sizes: Networking enables you to produce them economically while remaining agile. Automated machinery serves as the basis here.

---

# 4.0

Industry of  
the future

---

# Product Overview

	TruLaser	TruLaser Tube	TruPunch/TruMatic	TruBend
	<b>2D LASERS</b>	<b>LASER</b>	<b>PUNCHING +</b>	<b>BENDING</b>
		<b>TUBE CUTTING</b>	<b>PUNCH LASER</b>	
<b>LOADING</b>	LoadMaster 12 LiftMaster LiftMaster Compact LiftMaster Linear Basic LiftMaster Sort LiftMaster Linear LiftMaster Store LiftMaster Store Linear	LoadMaster Tube 28	SheetMaster SheetMaster Compact Cart systems 36 34	TruBend Cell 5000 TruBend Cell 7000
<b>UNLOADING</b>	14 16 18	Part removal station		
<b>SORTING</b>	SortMaster 24 14 20 22 22	30	34 SortMaster Box 38 SortMaster Box Linear 38	46 48
<b>DISPOSAL</b>		Scrap conveyor belt 30	GripMaster 40	
<b>TOOL HANDLING</b>			ToolMaster 42 ToolMaster Linear 42	ToolMaster Bend 50
<b>STORAGE + LOGISTICS SYSTEMS</b>	TruStore Series 1000 TruStore Series 3000 Large-scale storage systems			52 54 56
<b>SOFTWARE</b>				Intelligent software solutions for the entire sheet metal process chain 60



### Gain an overview.

Instead of wasting time searching, you stay on top of material and production with the touch of a button. Material is provided just-in-time, and you work more productively.

→ Produce more quickly and flexibly.



### Create leeway.

Forward-looking production and optimized procedures ensure organization and stability. A relaxed atmosphere prevails at the company, and customers value your reliability.

→ Keep customers and employees satisfied.



### Make ergonomics work for you.

Monotonous, stressful work is automated. Ergonomic procedures and appealing tasks motivate your employees and increase part quality.

→ Boost motivation and quality.



### Expand competitive advantages

Save space and better utilize your machines. This means you produce more economically – even around the clock. Your unit costs go down and you can plan more freely.

→ Win over your customers completely.

The image displays a production facility of the Franz Hof GmbH company.

■ Read the customer report at [www.mastersofsheetmetal.com/hof](http://www.mastersofsheetmetal.com/hof)

# Automation pays off.

Automation solutions impart clarity to your processes. Employees can concentrate on their core tasks and are more motivated. Your customers value your reliability as a supplier, while you operate more economically and increase your financial flexibility.

## FROM THE MACHINE TO THE INTELLIGENT SYSTEM.

Regardless of the extent to which you want to automate your production systems, TRUMPF can provide you with ideally matched automation, storage and software solutions that range from automated loading to networking of the production processes.

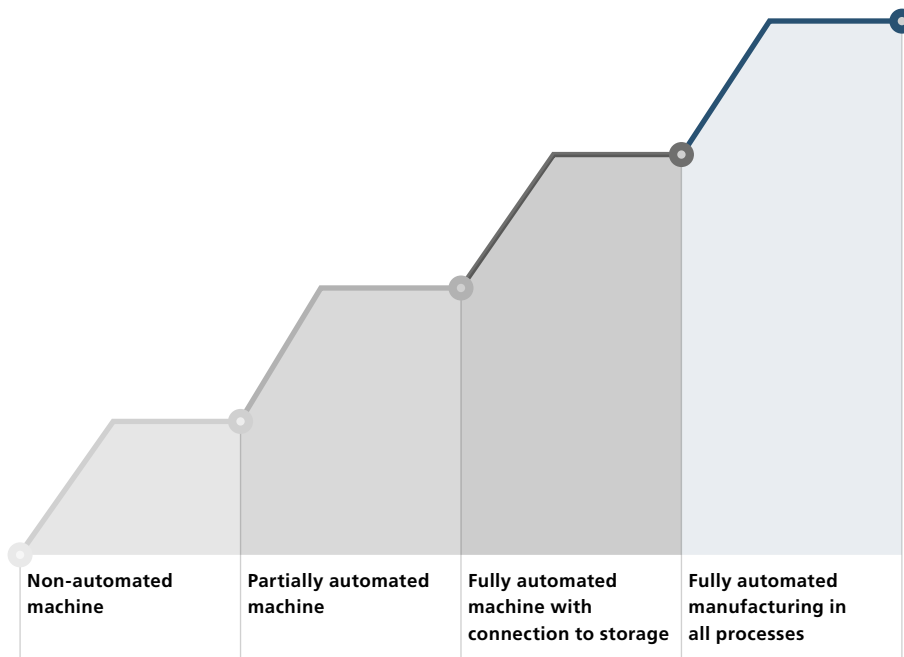

Increasing the degree of automation improves the reliability of your manufacturing processes, optimizes the capacity utilization of your machines, and ultimately boosts your output.



■ This video shows you just how automation pays off:  
[www.trumpf.info/cdwkzn](http://www.trumpf.info/cdwkzn)

# Choose the best – choose TRUMPF.

With TRUMPF, you have a strong automation partner on your side. You get a comprehensively integrated system tailored to your manufacturing process. When machinery, software, storage and automation are in perfect harmony, you can produce quickly, efficiently and flexibly – today and tomorrow.

## PASSIONATE ABOUT FINDING SOLUTIONS.

Put your worries behind you with TRUMPF's all-around, worry-free service. From conception of the initial idea to making it a reality, we accompany you every step of the way – with solid expertise and a hefty dose of personal dedication. What's special about this approach is that you have a dedicated contact at your side for the entire project.

## YOUR EXPERIENCED PARTNER.

Customers have been relying on TRUMPF automation for more than 30 years. During this time, more than 1,500 automated sheet metal processing systems have been put into service worldwide. In excess of 4,500 TRUMPF machines around the world are connected to storage systems. Take advantage of this wealth of experience – your TRUMPF expert advisor would be glad to assist you.

# Consulting and planning.

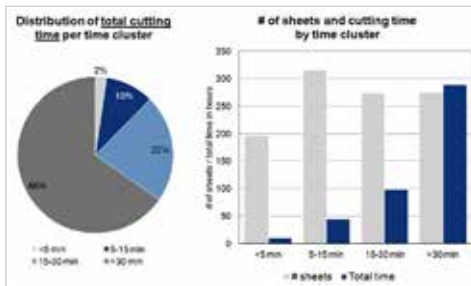

## Production Analysis

First we will develop a full understanding of your production and processes. Time studies and a cluster analysis are tools to identify potentials and determine your requirements for a logistics solution.

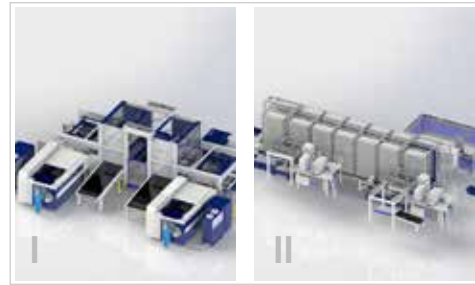

## Concept Development at Customer Facility

In the second stage, viable concepts and material flow options are developed by considering production requirements, goals, and the facility layout.

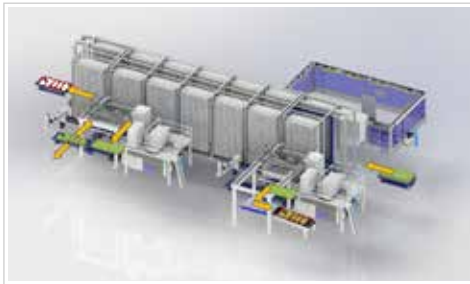

## Material Flow Concept

Based on concept layouts, all material flow options will be discussed with you in detail.

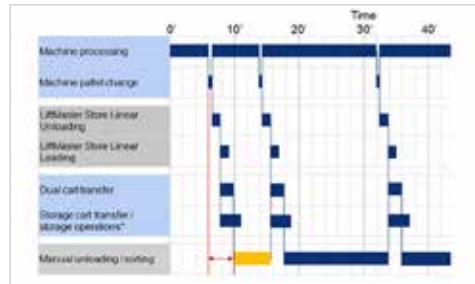

## Process Flow, Bottleneck Analysis and ROI

To ensure high efficiency and effectiveness of the concept, we will simulate a typical production flow and identify possible bottlenecks to discuss alternative solutions and strategies, and develop an ROI concept.



## Project Engineering

When the system that fulfills your goals is chosen, our engineering team will create detailed engineering layouts and begins project organization. In many cases a site survey is performed.

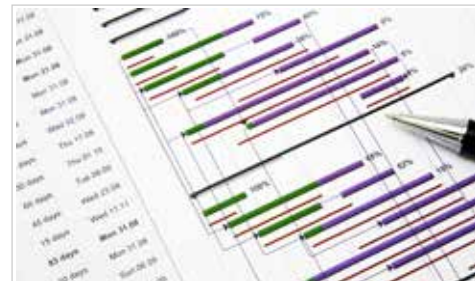

## Project and Installation Plan

As soon as the project organization is completed, a detailed project and installation plan is developed and presented to you. This way you will be well informed about all steps to prepare for the upcoming modernization.

# Smooth-flowing production.

Your networked production runs without a hitch because operators and machines make a perfect team. Furthermore, the machines communicate with each other and exchange information. This is made possible by automating the material flow and machine functions, as well as by linking processes through intelligent software.

"E-mail to the operator: Stoppage of the laser machine without malfunction."

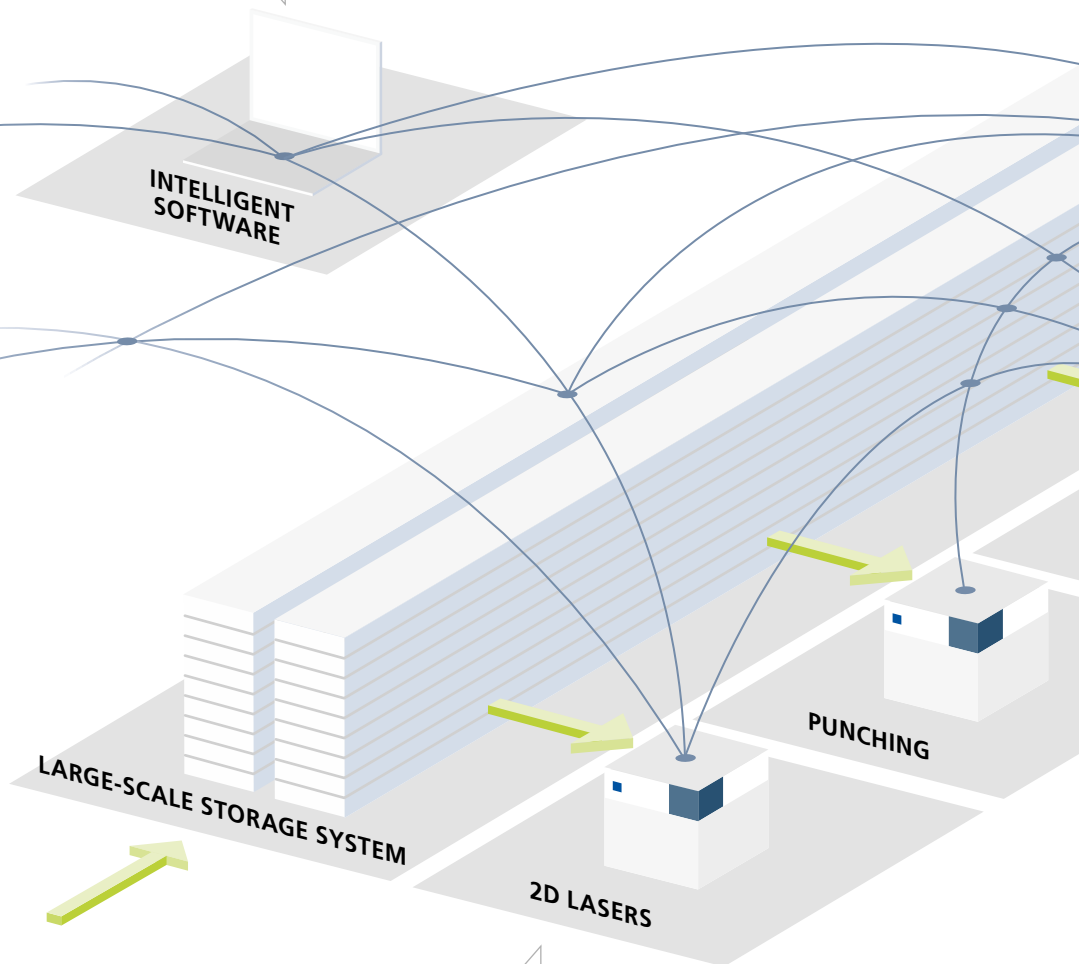

"The light beam to the optical sensor has been interrupted."



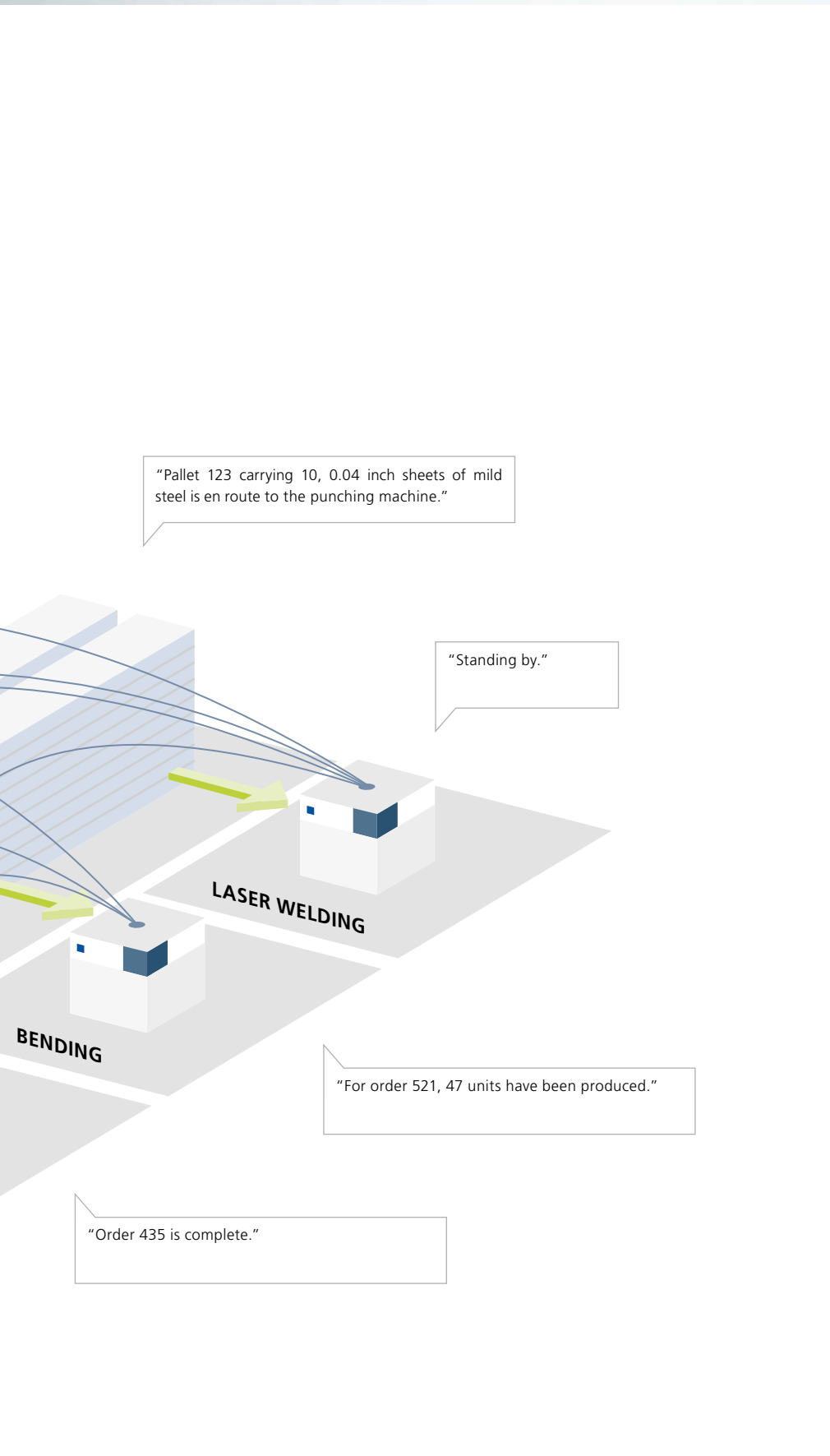

## DATA FLOW

### Intelligently connected

Machines report their production status to the central software program. From there you can plan and control your manufacturing process completely automatically. This minimizes your administrative effort and enables lean and smooth workflows. These benefits are also made possible by the direct line to technical support. The specialists are brought to your machine virtually via Visual Online Support (VOS).

## MATERIAL FLOW

### Loading, unloading, sorting, disposal

Automated material handling boosts the productivity of your machines. You can opt for unattended multi-shift operation, and can produce even small to medium-size batches economically and flexibly.

### Storage and logistics systems

An integrated storage system provides for an efficient flow of material, thus saving time, money and manufacturing space. Raw materials, semi-finished, and finished parts are stored and automatically conveyed to the processing stations as soon as they are needed.

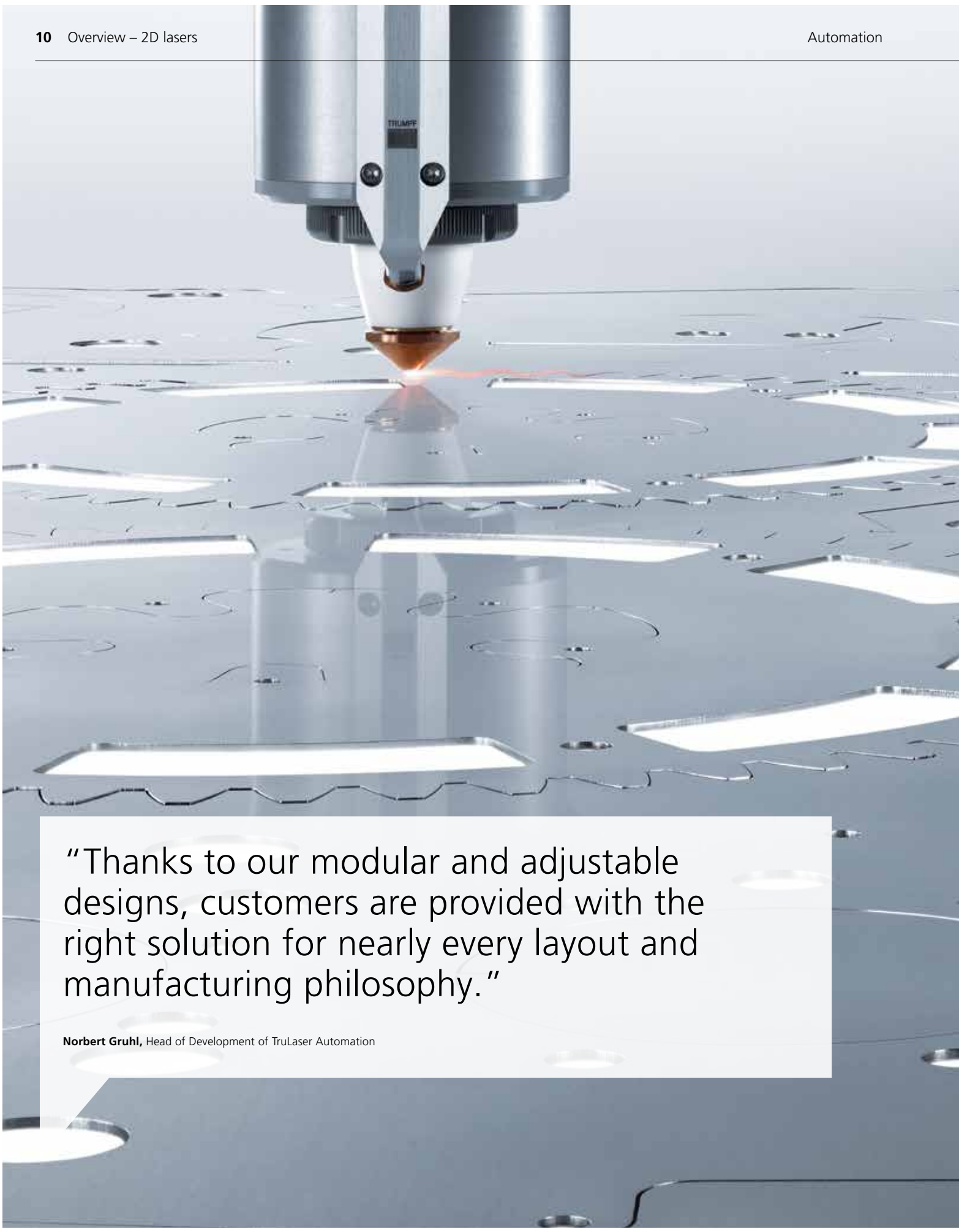

“Thanks to our modular and adjustable designs, customers are provided with the right solution for nearly every layout and manufacturing philosophy.”

**Norbert Gruhl**, Head of Development of TruLaser Automation

# Automated lasers make a convincing impression.

A wide range of modular automation components is available for your TruLaser cutting machines. This means you get a solution specifically matched to your needs – from a semi-automatic loader up to a fully automated machine with a storage connection.

## LOADING

**LoadMaster** \_\_\_\_\_ **12**  
Simple loading

## SORTING

**SortMaster** \_\_\_\_\_ **24**  
Fully automated sorting of small and large items

## LOADING + UNLOADING

**LiftMaster** \_\_\_\_\_ **14**  
Flexible loading and unloading

**LiftMaster Compact** \_\_\_\_\_ **16**  
Our best-in-class

**LiftMaster Linear Basic** \_\_\_\_\_ **18**  
The lean portal solution

**LiftMaster Linear** \_\_\_\_\_ **20**  
The universal portal solution

## LOADING + UNLOADING + SORTING

**LiftMaster Sort** \_\_\_\_\_ **14**  
Flexible loading, unloading and sorting

**LiftMaster Store** \_\_\_\_\_ **22**  
The fastest connection to storage

**LiftMaster Store Linear** \_\_\_\_\_ **22**  
The fastest connection to storage with multi-machine connection

Simple loading

# LoadMaster

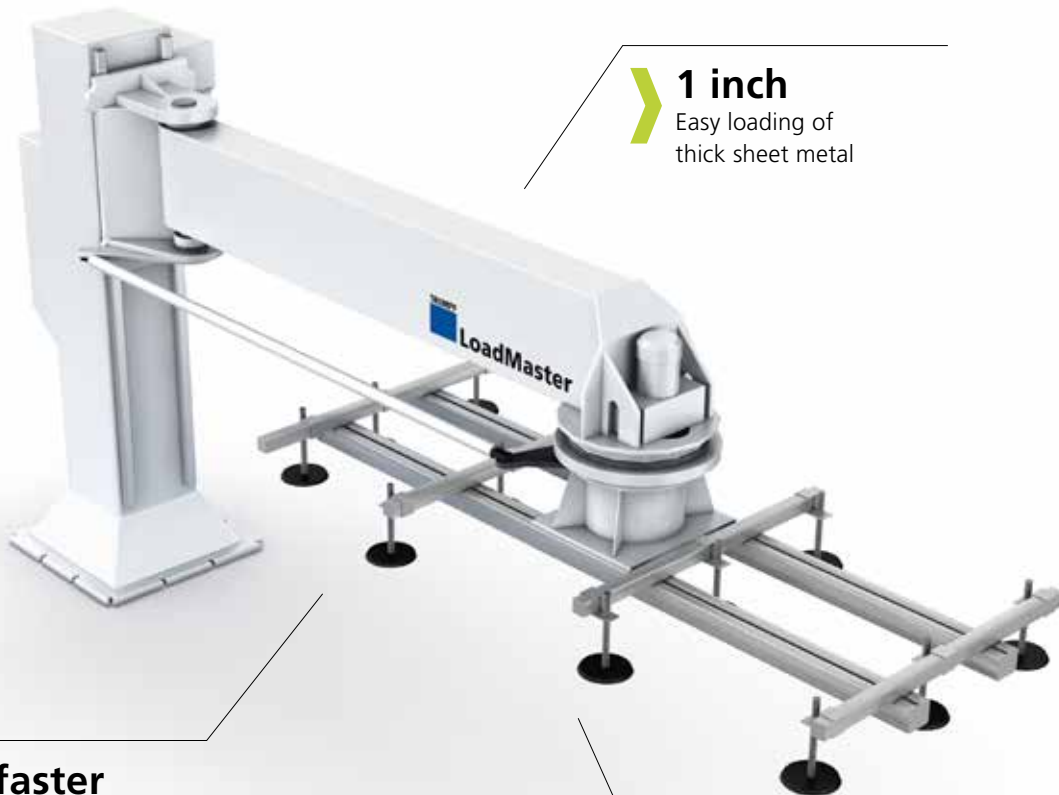

**1 inch**  
Easy loading of  
thick sheet metal

**Be faster**  
while producing more

**Reliable processes**  
even for thin sheets

**The LoadMaster universal loading unit automatically supplies your machine with raw sheets. A vacuum suction device moves the sheets from the loading station to the pallet changer and places them there. You can easily unload finished sheets by hand.**

With the LoadMaster, better utilize your machine's capacity and produce more at a reduced cost. Reliable processes are the key to this – for every sheet thickness. The peeler suction cup and fanning magnets provide additional help to ensure the process runs smoothly.

“With the LoadMaster, novices and advanced users alike benefit from an inexpensive and user-friendly material handling solution.”

**Mathis Schmidt**, Development – TruLaser Automation



Reliable processes for separating metal sheets increase productivity and reduce rejects.

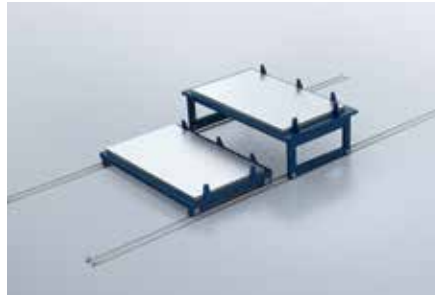

Simply linking the machine to the tube storage unit speeds up the material supply.



LoadMaster loading a TruLaser 3030.



■ Experience the **LoadMaster in action:**  
[www.trumpf.info/5pbko4](http://www.trumpf.info/5pbko4)

Technical data						
LoadMaster		Large format	Max format	Oversize format		
		1530	2040	2540	2060	2560
For TruLaser machine(s)		3030/3030 fiber	3040/3040 fiber	7040/7040 fiber	3060	8000
		5030/5030 fiber	5040/5040 fiber	8000	5060	
Max. sheet format	in x in	120 x 60	160 x 80	160 x 100	240 x 80	240 x 100
Min. sheet format	in x in	20 x 40	20 x 40	20 x 40	20 x 40	20 x 40
Max. sheet thickness	in	1	1	0.8	1	0.8
Max. sheet weight	lbs	2000	3500	3500	5300	5300
Typical equipment						
Loading station		■	■	■	■	■
Stripping equipment	N	□	□	□	□	□
Cart systems	N	□	□	□	□	□
Connection to storage	N	□	□	□	□	□

■ Standard    □ Optional    N Retrofitting might be possible  
 Subject to change. Only specifications in our quote and order confirmation are binding.

Flexible loading, unloading and sorting

# LiftMaster and LiftMaster Sort

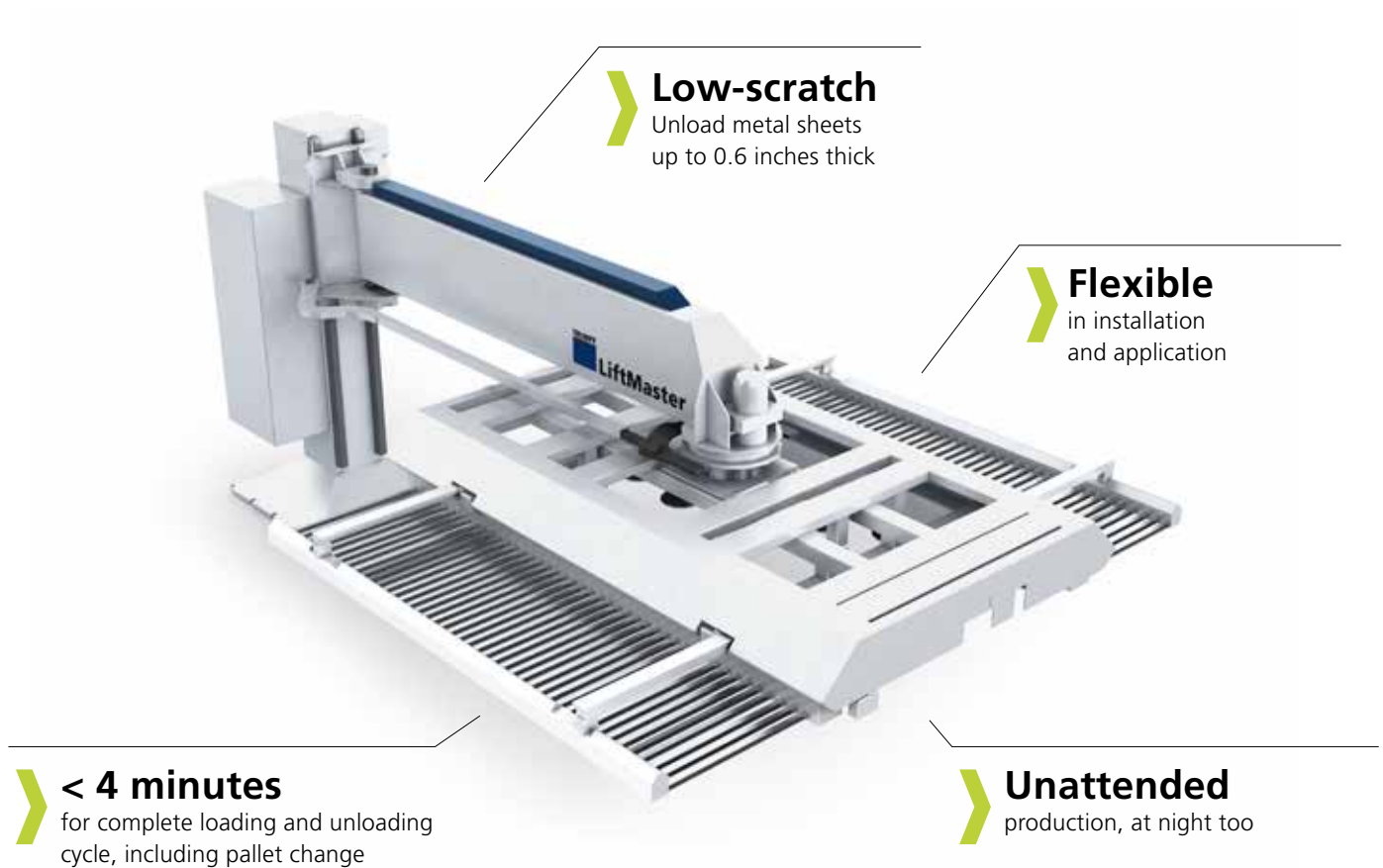

**With its various installation options, the LiftMaster lets you flexibly cover a wide range of automation functions – from loading and unloading to pallet handling and part removal.**

The LiftMaster swivel arm automatically adapts to the local conditions. Consequently, you can manufacture flexibly and increase your productivity in your normal environment. With the proven TRUMPF suction frame plus unloading rake, you gain a reliable and, upon request, low-scratch system for parts handling.



LiftMaster Sort with sorting functions: Finished parts are separated from the sheet skeleton and put in place.

“Only with a highly automated sheet metal manufacturing chain can we also counter the cheap competition in terms of costs.”

**Johann Hochstöger**, Fröling Heizkessel- und Behälterbau Ges. m.b.H.  
(a heating and boiler manufacturing company)

■ Read the full report at [www.mastersofsheetmetal.com/froeling](http://www.mastersofsheetmetal.com/froeling)



You can easily load and unload auxiliary pallets with the LiftMaster.

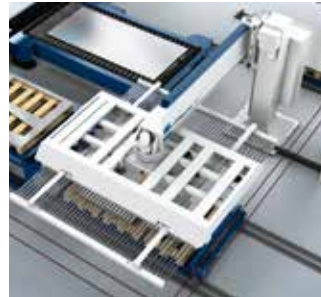

The LiftMaster Sort also lets you separate large parts from the sheet skeleton.



The LiftMaster loading and unloading a TruLaser 3030.



The LiftMaster indirectly connects a TruLaser 3030 to a TruStore 3030.



■ Experience the **LiftMaster and LiftMaster Sort in action:**  
[www.trumpf.info/xhu8dq](http://www.trumpf.info/xhu8dq)

Technical data				
LiftMaster / LiftMaster Sort		Large format	Max format	Oversize format
		1530	2040	2540
For TruLaser machine(s)		3030/3030 fiber	3040/3040 fiber	7040*/7040 fiber
		5030/5030 fiber	5040/5040 fiber	8000
Max. sheet format	in x in	120 x 60	160 x 80	160 x 100
Min. sheet format for loading/unloading	in x in	40 x 40/6 x 6	40 x 40/6 x 6	40 x 40/6 x 6
Max. sheet thickness for loading/unloading/unloading belt prongs/unloading auxiliary pallets	in	1/1/0.6/1	1/0.8/0.6/1	0.8/0.5/-/-
Max. sheet weight for loading/unloading	lbs	2000/2000	3500/2800	3500/2100
Typical equipment (LiftMaster / LiftMaster Sort)				
Suction frame/rake		■/■	■/■	■/-
Stripping equipment		■/■	■/■	■/-
SortMaster	N	□/□	□/□	□/-
Thin sheet separation	N	□/□	□/□	□/-
Part separation		-/■	-/■	-/-
Additional suction cup frame		-/□	-/□	-/-
Belt prongs	N	□/□	□/□	□/-
Cart systems	N	□/□	□/□	□/-
Auxiliary pallet mode	N	□/□	□/□	-/-
Connection to storage	N	□/□	□/□	□/-

■ Standard □ Optional N Retrofitting might be possible - Not available  
Subject to change. Only specifications in our quote and order confirmation are binding.

\* Not for LiftMaster Sort.

Our best-in-class

# LiftMaster Compact

**Unattended**  
production, at night, too

**< 90 seconds**  
for a complete loading and  
unloading cycle, including pallet  
change

**More  
productive**  
due to parallel  
loading and unloading

**Expandable**  
to include the manu-  
facturing cell with  
TruStore and PartMaster

**When you choose the LiftMaster Compact, you are choosing the fastest and most compact loading and unloading unit in the TRUMPF laser portfolio. While the suction plate unloads metal sheets onto the pallet changer, the rake frame load blanks onto the synchronous loader. This saves time, money and space. You can easily integrate this unit directly into TruStore or you can equip it with the manual PartMaster sorting station.**

As a dynamic and variable solution, the LiftMaster Compact is especially attractive when sheet runtimes are short – with or without a storage connection. In practice, the suction frame and rake integrated in the synchronous loader have proven themselves extensively, making it exceptionally reliable.





“We need to make production more effective and more profitable. The key is to keep manufacturing lean and that was why we elected to automate the new TruLaser 3030.”

**Harald Keller**, Keller Blechtechnik GmbH (a metals processor)

■ Read the full report at [www.mastersofsheetmetal.com/keller](http://www.mastersofsheetmetal.com/keller)



The optional PartMaster enables quick and ergonomic manual part sorting.



Full flexibility with a LiftMaster Compact and PartMaster integrated with a TruStore 3030.

Technical data			
LiftMaster Compact	Large format		Max format
	1530		2040
For TruLaser machine(s)	3030/3030 fiber		3040/3040 fiber
	5030/5030 fiber		5040/5040 fiber
			7040/7040 fiber
			8000
Max. sheet format	in x in	120 x 60	160 x 80
Min. sheet format for loading/unloading	in x in	40 x 40/6 x 6	40 x 40/6 x 6
Max. sheet thickness for loading/unloading/unloading belt prongs	in	1/1/0.6	1/0.8/0.6
Max. sheet weight for loading/unloading	lbs	2000 /2000	3500/2800
Max. loading weight of the finished part pallets	lbs	6614	11023
Max. loading stack height – standalone/TruStore/large-scale storage system	in	12/6.7/5	12/3.5/5
Max. unloading stack height – standalone/TruStore/large-scale storage system	in	10/6.7/8	10/6.7/8
Typical equipment			
Synchronous loader		■	■
Unloading rake		■	■
Thin sheet separation	N	□	□
Belt prong	N	□	□
PartMaster (up to 0.25 in)	N	□	-
TruStore integration	N	□	□
Cart systems	N	□	□
Connection to storage	N	□	□

■ Standard    □ Optional    N Retrofitting might be possible    – Not available  
Subject to change. Only specifications in our quote and order confirmation are binding.

The lean portal solution

# LiftMaster Linear Basic

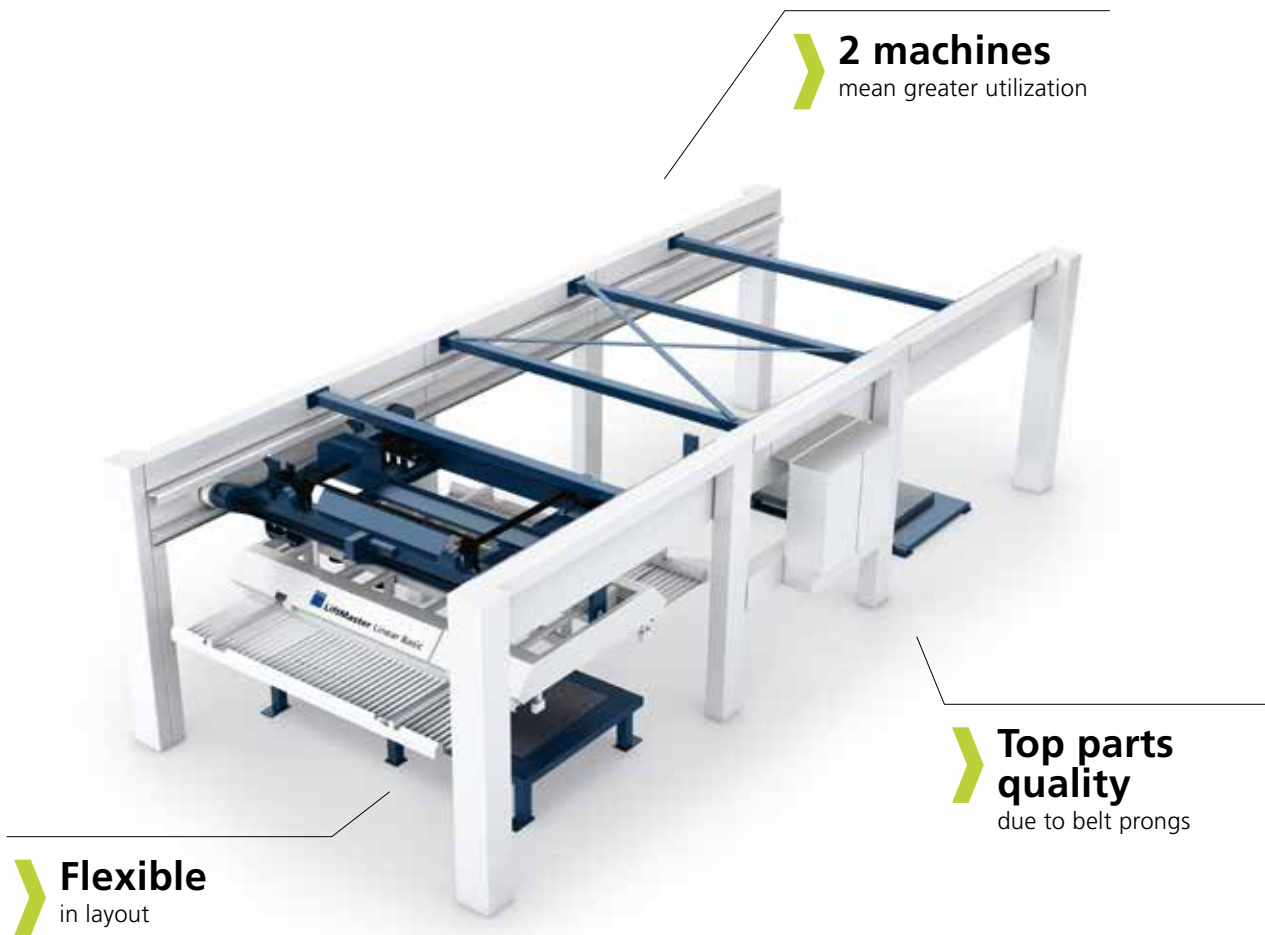

**Simple, compact, reliable: The LiftMaster Linear Basic is a lean solution for the loading and unloading of sheets – one that offers optimum value for the money. Compared to the LiftMaster, it has a 15% smaller footprint. Cart systems enable an indirect connection to a storage system.**

You can simultaneously connect multiple machines to your LiftMaster Linear Basic. This way you boost the utilization from one to two machines at a maximum of four stations. In doing so you integrate cart systems, loading stations and deposit platforms just as flexibly and universally as with the LiftMaster Linear.

“By focusing completely on loading and unloading, the LiftMaster Linear Basic offers very good value.”

Patrick Bauer, Product Marketing for Automation and Processes



Reliable loading with the TRUMPF suction frame.



Higher parts quality due to low-scratch unloading with belt prongs.



LiftMaster Linear Basic on a TruLaser 3030.



Multi-machine connection with LiftMaster Linear Basic.



■ Experience the **LiftMaster Linear Basic in action:**  
[www.trumpf.info/cn6b1h](http://www.trumpf.info/cn6b1h)

Technical data		
LiftMaster Linear Basic		<b>Large format</b>
		<b>1530</b>
For TruLaser machine(s)		3030
		3030 fiber
		5030
		5030 fiber
Max. sheet format	in x in	120 x 60
Min. sheet format for loading/unloading	in x in	40 x 40/6 x 6
Min. sheet format for unloading	in x in	6 x 6
Max. sheet thickness for loading/unloading/unloading belt prongs	in	1/1/0.6
Max. sheet weight for loading/unloading	lbs	2000/2000
Typical equipment		
Suction frame/rake		■
Stripping equipment		■
Thin sheet separation	N	□
Belt prongs	N	□
Cart systems	N	□
Multi-machine connection		□
Connection to storage	N	□

■ Standard    □ Optional    N Retrofitting might be possible  
 Subject to change. Only specifications in our quote and order confirmation are binding.

The universal portal solution

# LiftMaster Linear

**20 ft x 6.5 ft**  
maximum sheet size

**3 machines**  
or storage units can be connected

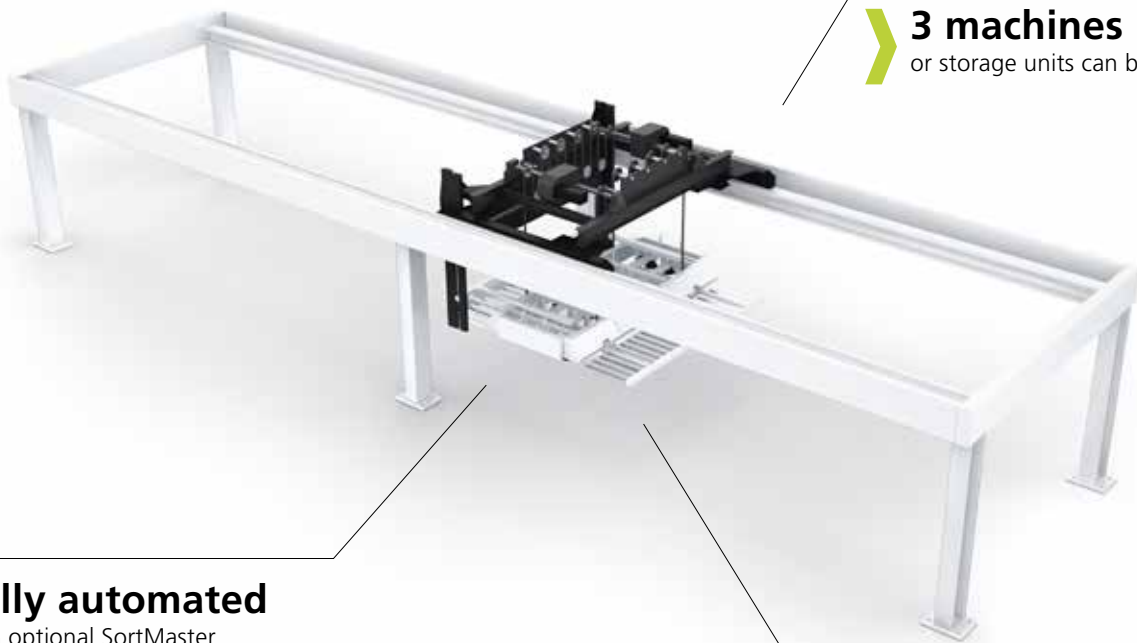

**Fully automated**  
with optional SortMaster

**Uniquely productive**  
due to skeleton separation

**Using its linear axis, the LiftMaster Linear loads and unloads up to three machines at a maximum of six stations. At the stations, you can selectively integrate cart systems, machines, loading stations or unloading platforms.**

The versatile LiftMaster Linear can easily handle nearly any application. The sort extension(s) or sheet skeleton extension(s) separate the good parts from the sheet skeleton. Adding in the SortMaster gives you a fully automated, reliable and stable manufacturing cell in which the good parts can even be placed with the appropriate orientation for the follow-up process.

“The first standard portal solution with which customers can load and unload sheets measuring 20 ft x 6.5 ft.”

Norbert Gruhl, Head of Development for TruLaser Automation

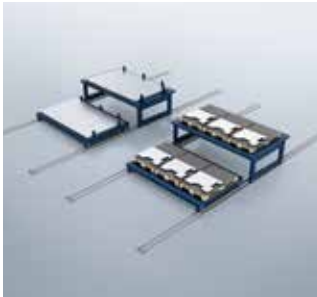

Simple connection of the machine to a raw material storage area for faster material supply.

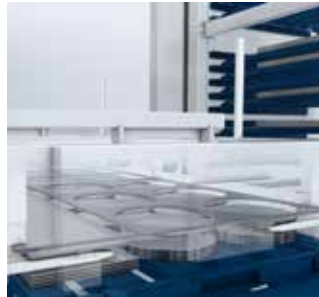

More productive, due to skeleton separation; produced in a hub and in less than one minute per sheet.

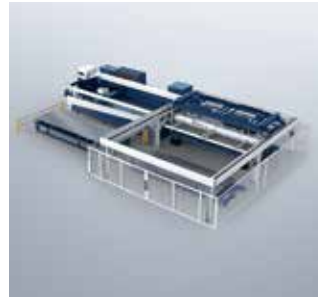

TruLaser 5060 with LiftMaster Linear and double cart.



Multi-machine connection with three TruLaser 5060 and LiftMaster Linear.

Technical data					
LiftMaster Linear		Large format		Max format	Oversize format
		1530		2040	2060
For TruLaser machine(s)		3030/3030 fiber		3040/3040 fiber	3060
		5030/5030 fiber		5040/5040 fiber	5060
				7040/7040 fiber	
				8000	
Max. sheet format	in x in	120 x 60		160 x 80	240 x 80
Min. sheet format for loading/unloading	in x in	40 x 40/6 x 6		40 x 40/6 x 6	40 x 40/6 x 6
Max. sheet thickness for loading/unloading/unloading belt prongs/unloading auxiliary pallets	in	1/1/0.6/1		1/0.8/0.6/1	1/1/-/-
Max. sheet weight for loading/unloading	lbs	2000/2000		3500/2800	5100/5100
Typical equipment					
Suction frame/rake			■	■	■
Stripping equipment			■	■	■
SortMaster	N	□	□	□	-
Thin sheet separation	N	□	□	□	□
Part separation		□	□	□	-
Additional suction cup frame		□	□	□	-
Skeleton separation		□	-	-	-
Belt prongs	N	□	□	□	-
Auxiliary pallet mode	N	□	□	□	-
Cart systems	N	□	□	□	□
Multi-machine connection		□	□	□	□
Connection to storage	N	□	□	□	□

■ Standard □ Optional N Retrofitting might be possible - Not available  
Subject to change. Only specifications in our quote and order confirmation are binding.

The fastest connection to storage with multi-machine connection

# LiftMaster Store and LiftMaster Store Linear

**More productive**  
with direct storage access

**Expandable**  
to include the production cell with TruStore and SortMaster



**100 seconds**  
for a complete loading and unloading cycle, including pallet change, with the synchronous loader

**Unbeatable**  
due to the skeleton separation

**As a portal solution directly connected to a storage system, the LiftMaster Store needs very little space and provides leeway in how you design your production.**

The LiftMaster Store derives its top performance from a variety of proven TRUMPF technologies. These include the suction frame with rake for reliable loading and unloading, as well as the synchronous loader for increasing productivity. With its independent pallet picker crane, the LiftMaster Store is able to quickly access pallets in the storage system. This makes it particularly well suited for automatic skeleton separation.



With multiple stations, the LiftMaster Store Linear can be connected to up to three machines.

“In order to greatly reduce access times to storage, the LiftMaster Store is connected directly to the storage system and customers can opt for the synchronous loader.”

**Mathis Schmidt**, Development – TruLaser Automation

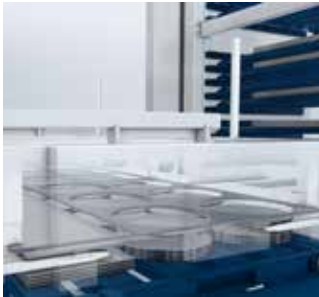

More productive, due to skeleton separation; produced in one stroke and in less than one minute per sheet.



The synchronous loader provides for parallel loading and unloading, thus increasing productivity.



LiftMaster Store connects a TruLaser 5030 directly to a TruStore 3030 and SortMaster.



Multi-machine connection with LiftMaster Store Linear and TruStore 3030.



■ Experience the **LiftMaster Store in action:**  
[www.trumpf.info/a0tcmn](http://www.trumpf.info/a0tcmn)

Technical data			
LiftMaster Store / LiftMaster Store Linear		Large format	Max format
		1530	2040
For TruLaser machine(s)		3030/3030 fiber	3040/3040 fiber
		5030/5030 fiber	5040/5040 fiber
			7040/7040 fiber
			8000
Max. sheet format	in x in	120 x 60	160 x 80
Min. sheet format for loading/unloading	in x in	40 x 40/6 x 6	40 x 40/6 x 6
Max. sheet thickness for loading/unloading/unloading belt prongs	in	1/1/0.6	1/0.8/0.6
Max. sheet weight for loading/unloading	lbs	2000/2000	3500/2800
Typical equipment (LiftMaster Store / LiftMaster Store Linear)			
Suction frame/rake/peeling equipment		■/■	■/■
SortMaster	N	□/□	□/□
Thin sheet/part separation	N	□/□	□/□
Additional suction frame		□/□	□/□
Skeleton separation		□/□	-/-
Synchronous loader		□/□	-/-
Belt prongs	N	□/□	□/□
Auxiliary pallet mode	N	□/□	□/□
Multi-machine connection		-/□	-/□
TruStore/STOPA integration	N	□/□	□/□

■ Standard    □ Optional    N Retrofitting might be possible    - Not available  
 Subject to change. Only specifications in our quote and order confirmation are binding.

Fully automated sorting of small and large items

# SortMaster

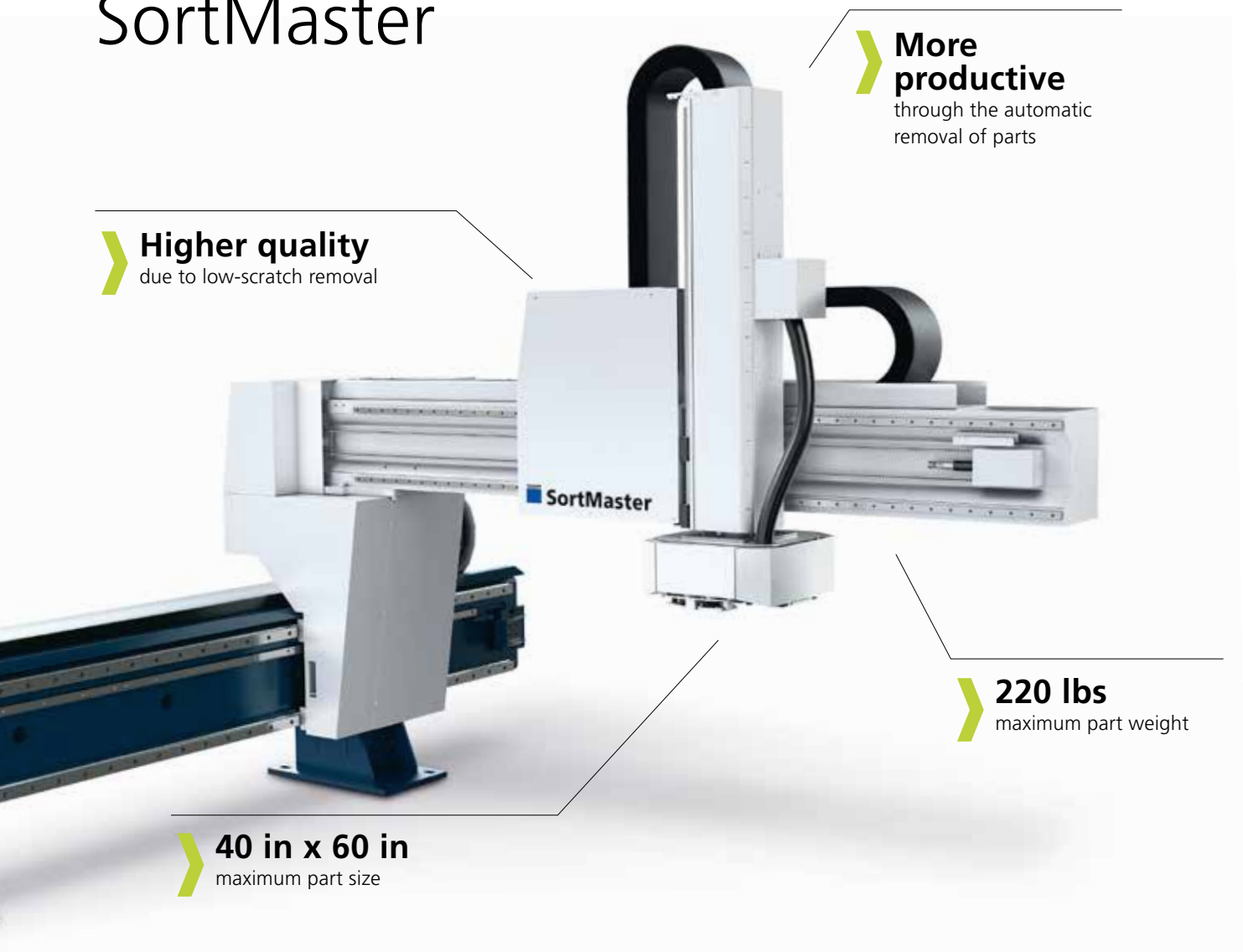

**Higher quality**  
due to low-scratch removal

**More productive**  
through the automatic  
removal of parts

**40 in x 60 in**  
maximum part size

**220 lbs**  
maximum part weight

**The SortMaster removes, sorts and stacks finished cut parts. With the SortMaster, you can also operate your laser machine completely automatically by connecting it to a storage system using a LiftMaster. This means you can manufacture your products as requested, reliably and even around the clock.**

Smart functions resolve potential disruption independently. For example, through the automatic separation check: If a part does not fall from the skeleton, the gripper head separates it by shaking the skeleton. If a part does not release, the gripper head separates it by shaking it from the sheet skeleton.



“Today we have achieved the optimum degree of automation. Now we are able to manufacture many parts ourselves, parts we would otherwise have to outsource.”

**Daniel Peltier**, HEIN Backöfen & Kältetechnik (a manufacturer of commercial ovens and refrigeration equipment)

■ Read the full report at [www.mastersofsheetmetal.com/hein](http://www.mastersofsheetmetal.com/hein)



Additional gripper removes parts up to 40 x 60 in and can be easily connected by means of gripper coupling.



Smart functions: Monitoring of the part separation and, with the vibration applied at the gripper head, more effective separation of the good parts from the sheet skeleton.



TruLaser 5030 with SortMaster, connected directly to TruStore 3030 by means of the LiftMaster Store.



TruLaser 3030 with LiftMaster Sort, SortMaster and cart systems.



■ Experience the **SortMaster in action:**  
[www.trumpf.info/4do5eh](http://www.trumpf.info/4do5eh)

Technical data			
SortMaster		Large format	Max format
		1530	2040
For TruLaser machine(s)		3030/3030 fiber	3040/3040 fiber
		5030/5030 fiber	5040/5040 fiber
Max. parts weight	lbs	220	220
Min./max. part size	in	1.2 x 3.1/40 x 60	1.2 x 3.1/40 x 60
Typical equipment			
Gripper head		■	■
Magnetic suction gripper		■	■
Spreadable suction cup slats		■	■
Gripper coupling		■	■
Cleaning brushes		■	■
Cart systems	N	□	□
Connection to storage	N	□	□

■ Standard   □ Optional   N Retrofitting might be possible  
Subject to change. Only specifications in our quote and order confirmation are binding.



“We have developed a machine that makes fully automated production possible. This is crucial for the competitiveness of our customers.”

**Torsten Popp**, Development – TruLaser Tube

# Automated laser tube cutting.

Your laser tube cutting machine operates automatically – and reliably, around the clock – and thus pays for itself much more quickly. Take advantage of the fully automated material handling offered by the very accessible TruLaser Tube machines.

## LOADING

### **LoadMaster Tube** \_\_\_\_\_ **28**

Loading of tubes and profiles

## UNLOADING + SORTING

### **Part removal station** \_\_\_\_\_ **30**

Gentle unloading and sorting

## DISPOSAL

### **Scrap conveyor belt** \_\_\_\_\_ **30**

Removal of scrap parallel to production

Loading of tubes and profiles

# LoadMaster Tube

**Intelligent**  
process management

Up to **30 ft**  
in tube length



Also flexible with  
**small batch sizes**

**With the LoadMaster Tube, you benefit from minimum setup times. The tube magazine has a capacity of up to four metric tons of raw material, which the loading unit conveys after a plausibility check.**

To do this, the machine software compares the geometry of the tubes with stored data and consequently ensures trouble-free operation. The gripper system automatically transfers the measured tube to the machine. You can load small series quite easily by conveyor system or by hand. With Smart Profile Detection, you can also process exceptional profiles with high reliability. The innovative procedure detects the angular position and orientation of the tube while loading and automatically positioning the clamping device accordingly.

“Our TruLaser Tube 7000 tube magazine has a capacity of 4 metric tons of material; the tubes are automatically checked and loaded. This way we can also produce unattended at night.”

Udo Reichardt, Reichardt Metallverarbeitung (a manufacturer of parts and subassemblies)



Wide clamping precisely guides the workpieces to the cutting head.



Fully automated material handling on the TruLaser Tube 7000: loading, unloading, sorting, discharging scrap.



LoadMaster Tube on the TruLaser Tube 5000.



The swivel-mounted conveyor system on the TruLaser Tube 7000 for small batch sizes and special profiles.



■ Experience the **LoadMaster Tube in action:**  
[www.trumpf.info/o4eysv](http://www.trumpf.info/o4eysv)

Technical data			
LoadMaster Tube		TruLaser Tube 5000	TruLaser Tube 7000
Max. tube length for automatic loading	in	256/315	256/362
Max. outer circle diameter	in	6	8/10
Max. tube line weight	lbs/ft	13.5	17/25
Max. tube weight	lbs	265	331/496
Max. bundle weight	lbs	8800	8800
Typical equipment			
Automatic setup		□	■
Conveyor system		■	□
Low-scratch model	N	□	□
Tube diameter 0.6 in	N	□	■
Front attachment of LoadMaster Tube		□	□
Smart Profile Detection	N	□	□

■ Standard □ Optional N Retrofitting might be possible  
 Subject to change. Only specifications in our quote and order confirmation are binding.

Gentle unloading and sorting

# Part removal station and scrap conveyor belt

Scrap disposal  
**parallel to production**



Flexible  
**parts sorting**

Protective  
**finished parts buffer**

**The TruLaser Tube part removal station takes special care when unloading your finished parts on conveyor tables, in wire mesh boxes or in containers. All components can be placed as desired.**

Conveyor tables serve as finished parts buffers; parts can be taken from here at an ergonomic height parallel to production. The flexible part removal station of the TruLaser Tube 7000 also sorts your finished parts. The scrap conveyor belt discharges scrap into waiting boxes parallel to production.

“We remove cut parts — using either the conveyor table or the part removal station — directly into a wire mesh box. This way, we can configure the storage area for finished parts to match the job.”

**Frank Steinhart**, H. Steinhart Metallwarenfabrik GmbH & Co. KG (processor of tubes and pipes)

■ Read the full report at [www.mastersofsheetmetal.com/steinhart](http://www.mastersofsheetmetal.com/steinhart)



Flexible parts sorting on the TruLaser Tube 7000.



TruLaser Tube 5000 with part removal station and scrap conveyor belt.



■ Experience the **part removal station in action:**  
[www.trumpf.info/qirs9p](http://www.trumpf.info/qirs9p)

Technical data			
Part removal station		TruLaser Tube 5000	TruLaser Tube 7000
Max. finished part length at part removal station	in	120/260	120/180/260
Max. finished part length at part removal station with optional finished length + 59 in	in	180/315	180/140/315
Max. outer circle diameter	in	6	8/10
Typical equipment			
Automatic setup		■	■
Small parts slide		■	■
Parts separated and parts fallen sensor		■	■
Numerically controlled (NC) sorting possibility		-	■
Finished part length + 59 in	N	□	□
Conveyor table	N	□	□
Scrap conveyor belt		■	□

■ Standard   □ Optional   N Retrofitting might be possible   - Not available  
Subject to change. Only specifications in our quote and order confirmation are binding.



“To enable customers to maximize their productivity with TRUMPF punching or punch laser machines, we adapt our automation to the respective performance class.”

**Marcus Busch**, Head of Development for TruPunch/TruMatic Automation



# Automated punching.

For your combination punch laser or punching machine, you can select from a full range of ideally matched automation solutions. Benefit from the turnkey concepts provided by a full-range supplier – including machinery, automation, programming and production control technology.

## LOADING + UNLOADING + SORTING

### **SheetMaster** \_\_\_\_\_ **34**

Loading of raw materials, as well as the unloading and sorting of finished parts

## LOADING + UNLOADING

### **Cart systems** \_\_\_\_\_ **34**

Customized extension of the SheetMaster

### **SheetMaster Compact** \_\_\_\_\_ **36**

Space-saving entry-level solution for loading raw materials and unloading microjoint sheets

## SORTING

### **SortMaster Box** \_\_\_\_\_ **38**

Sorting of finished parts

### **SortMaster Box Linear** \_\_\_\_\_ **38**

Sorting of finished parts into containers, moving linearly

## DISPOSAL

### **GripMaster** \_\_\_\_\_ **40**

Unloading of the sheet skeleton

## TOOL HANDLING

### **ToolMaster / ToolMaster Linear / integrated tool changer** \_\_\_\_\_ **42**

Flexible storage and changing of tools

Loading of raw materials, as well as the unloading and sorting of finished parts

# SheetMaster and cart systems

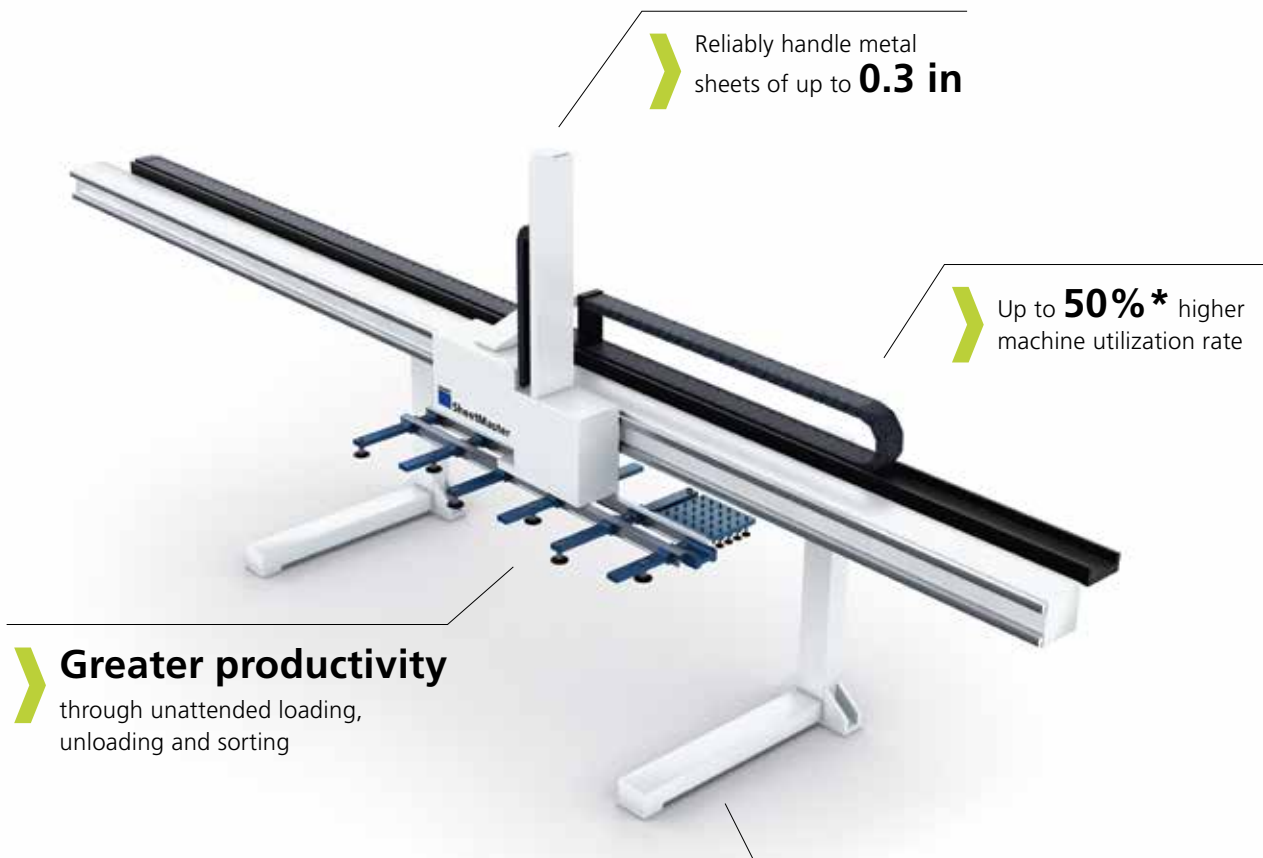

Reliably handle metal sheets of up to **0.3 in**

Up to **50%\*** higher machine utilization rate

**Greater productivity**  
through unattended loading,  
unloading and sorting

**Can be expanded**  
to include a production cell with  
TruStore, SortMaster Box and  
GripMaster

**The SheetMaster loads and unloads your punching or combination punch laser machine and sorts parts reliably. Suction cups pick up metal sheets or pre-cut sheets from the loading station and transport them to the machine table. SheetMaster places the finished parts on a unloading platform. By using a wide range of suction units, you can process with an enormous variety of applications depending on the machine type.**

Adding a SortMaster Pallet significantly increases your unloading capacity. Alternatively, you can use cart systems on rails or with belt drive, to load and unload more parts. Using carts also makes it possible to connect your machine to compact and large-scale storage systems.

\* Two shifts during the day, with an additional unattended shift at night.

“Based on our need for three-shift operations and weekend work, and to prepare for the future, we had to purchase a highly productive, automated system.”

**Michael Kohlmann**, Regiolux GmbH

■ Read the full report at [www.mastersofsheetmetal.com/regiolux](http://www.mastersofsheetmetal.com/regiolux)

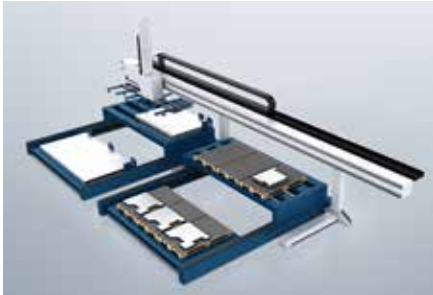

Cart system with belt drive for loading and unloading.



TruPunch 5000 automates with the SheetMaster and ToolMaster Linear.



TruMatic 7000 connected to the TruStore 3030 with SheetMaster, loading double cart on rails, SortMaster Box, GripMaster, and ToolMaster.

Technical data									
SheetMaster		TruPunch 3000		TruPunch 5000		TruMatic 6000		TruMatic 7000	
		Medium format	Large format	Medium format	Large format	Medium format	Large format	Medium format	Large format
		3025	3030	5025	5030	6125	6130	7125	7130
Max. sheet format	in x in	100 x 50	120 x 60	100 x 50	120 x 60	100 x 50	120 x 60	100 x 50	120 x 60
Max. sheet format for loading	in x in	24 x 14	24 x 14	24 x 14.5	24 x 14.5	24 x 14	24 x 14	24 x 24	24 x 24
Min. part size for unloading	in x in	4 x 1	4 x 1	7 x 7	7 x 7	6 x 7 (punching) 43 x 1 (laser treatment)		6 x 6	6 x 6
Sheet thicknesses	in	0.03–0.25	0.03–0.25	0.03–0.3	0.03–0.3	0.03–0.3	0.03–0.3	0.03–0.3	0.03–0.3
Max. sheet weight	lbs	353	507	441	507	353	507	485	628
Typical equipment									
Loading station		■	■	■	■	■/■	■/■	■	■
Unloading platform		■	■	■	■	■/■	■/–	■	■
Suction modules/ plate/slats		□	□	□	■	■/■	■/■	■	■
Sorting axis		–	–	–	–	–/–	–/–	■	■
Loading/unloading parallel to production	N	□	□	□	□	□/■	□/■	□	□
Loading table	N	–	–	□	□	–	–	–	–
Cart systems	N	□	□	□	□	□/□	□/■	□	□
Connection to storage	N	□	□	□	□	□/□	□/□	□	□

■ Standard □ Optional N Retrofitting might be possible – Not available  
Subject to change. Only specifications in our quote and order confirmation are binding.

Space-saving, entry-level solution for loading and unloading

# SheetMaster Compact

**Unattended**  
production, at night too

**More productive**  
through unattended  
loading and unloading

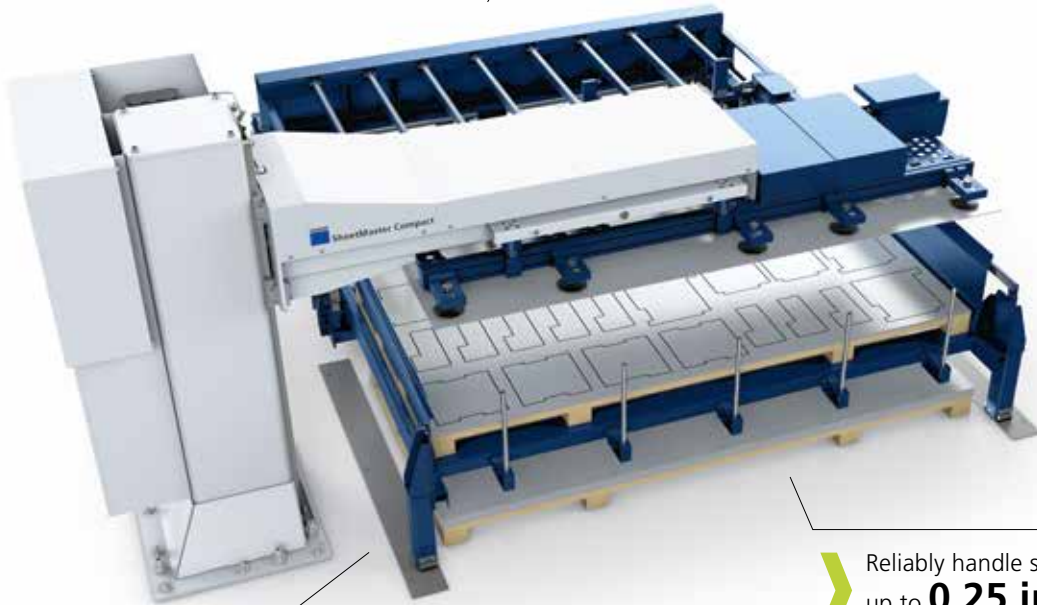

**90 seconds**  
for a complete loading  
and unloading cycle

Reliably handle sheets of  
up to **0.25 in**

**The space-saving SheetMaster Compact is your gateway to automated punching. It loads your TruPunch 2000 or TruPunch 3000 with sheets or pre-cut sheets and unloads microjoint sheets and sheet skeletons. Consequently, your system works much more productively without taking up much more space.**

With the SheetMaster Compact, the TruPunch processes microjoint sheets reliably and efficiently. Alternatively, you can use this flexible aid to unload sheet skeletons for example, if all finished parts are to be ejected through the TruPunch 3000 part removal flap.

“The new TruPunch 3000 is faster than our old machine and, in combination with the SheetMaster Compact, it increases the yield even further.”

Phil Taylor, PKD Precision Sheet Metal Ltd.



Low-scratch placement of the microjoint sheets with the belt prongs.

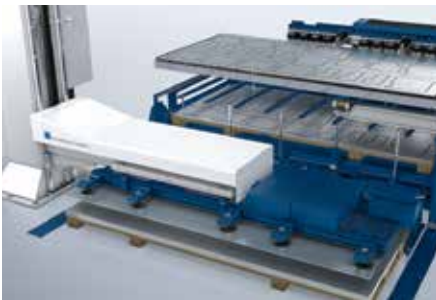

Carefully prepared loading before unloading saves time.



SheetMaster Compact on a TruPunch 2000.



■ Experience the **SheetMaster Compact in action:** [www.trumpf.info/mk19eo](http://www.trumpf.info/mk19eo)

Technical data		
SheetMaster Compact		Medium format
For TruPunch machine(s)		2000
		3000
Max. sheet format	in x in	100 x 50
Min. sheet size	in x in	67 x 14
Sheet thickness for loading/unloading	in	0.03–0.5/0.03–0.15*
Max. sheet weight for loading/unloading	lbs	350/200
Typical equipment		
Peeler suction cup		■
Double sheet detection		■
Positioning aid	N	□
Additional suction cup package	N	□

■ Standard      □ Optional      N Retrofitting might be possible  
 Subject to change. Only specifications in our quote and order confirmation are binding.

\* Restrictions due to microjoint sheet processing.

Unloading and sorting of finished parts

# SortMaster Box and SortMaster Box Linear

**Four types of parts** can be separated easily and flexibly



**100% easy** to integrate into intralogistics

**More productive** with the removal and sorting of parts parallel to production

**Small parts that fall through the punching or laser flap are automatically sorted by the SortMaster Box or SortMaster Box Linear into as many as four boxes. The parts must not be larger than 20 in x 20 in. Since the unattended sorting takes place during the manufacturing process, the entire system becomes more productive.**

With the SortMaster Box, the containers are arranged in a carousel; with the SortMaster Box Linear, small parts fall into boxes that move along a line. As a result of an additional conveyor belt and another part removal flap, the linear solution is particularly scratch-free. In both versions, the containers can be removed with a pallet jack. Simply select the version that best suits your facility layout.



SortMaster Box Linear: simple, particularly low-scratch sorting into linearly movable containers.

“SortMaster Box makes the rapid removal of parts even easier and more reliable because it eliminates manual sorting.”

**Marcus Busch**, Head of Development for TruPunch/TruMatic Automation



TruPunch 3000 with a SheetMaster, integrated tool changer, and SortMaster Box Linear.



TruPunch 5000 with a SheetMaster, SortMaster Box, GripMaster and ToolMaster Linear.

Technical data			
		SortMaster Box	SortMaster Box Linear
For TruPunch machine(s)		5000*	3000
			5000
		6000	
		7000	
Max. part size	in x in	20 x 20	20 x 20
Max. number of boxes		4	4

\* Not in conjunction with skeleton-free punching.

Subject to change. Only specifications in our quote and order confirmation are binding.

Easily dispose of sheet skeletons

# GripMaster

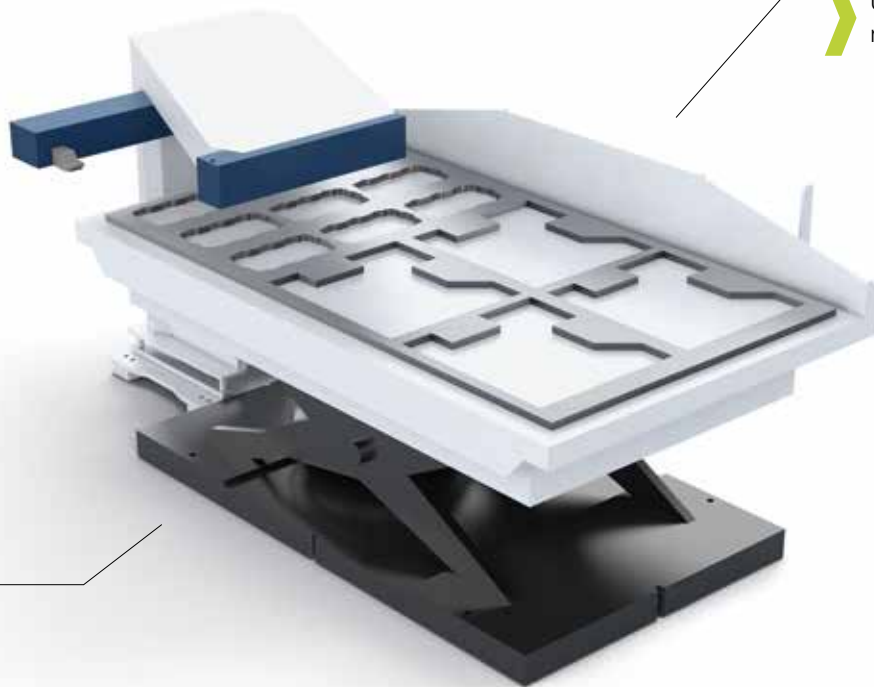

Up to **50%\*** higher machine utilization rate

**100%**  
easy to integrate

**It's doesn't matter whether you discard sheet skeletons as a whole or shredded – simply choose the solution that's right for you.**

GripMaster lets you get a grip on sheet skeletons and remainder strips. It removes and stacks them automatically on a scissor lift table with a sheet skeleton pallet. The ShearMaster makes it easier to dispose of scrap. It draws the sheet skeleton from the machine onto its conveyor table and shreds the material into manageable strips using a shearing unit. Whatever is left over from the skeleton-free punching is disposed of by the DisposeMaster. It sorts the shredded sheet skeleton and slugs according to material type.

**Safer** as a result of the unattended removal and stacking of sheet skeletons

\* Two shifts during the day, with an additional unattended night shift in combination with SheetMaster.



“Because the customer alone can judge the value of scrap, TRUMPF offers solutions for sheet skeletons as well as for cut-up scrap.”

Tino Fröde, Development – TruPunch/TruMatic Automation



TruPunch 3000 with SheetMaster, SortMaster Box Linear.



TruPunch 5000 with SheetMaster, SortMaster Box, GripMaster and ToolMaster Linear.

Technical data		
<b>Sheet skeleton / scrap handling</b>		<b>GripMaster</b>
<b>For TruPunch machine(s)</b>		5000
		6000
		7000
Steel sheet thickness	iin	Depending on machine
Aluminum sheet thickness	in	
Stainless steel sheet thickness	in	
Max. scrap size	in x in	Depending on sheet format
Max. stack height	in	16
Max. carrying capacity of scissor table	lbs	11000
Max. carrying capacity	lbs	4409 (sheet skeleton pallet)

\* Only in conjunction with skeleton-free punching.  
Subject to change. Only specifications in our quote and order confirmation are binding.

Flexible tool systems

# ToolMaster, ToolMaster Linear and integrated tool changer

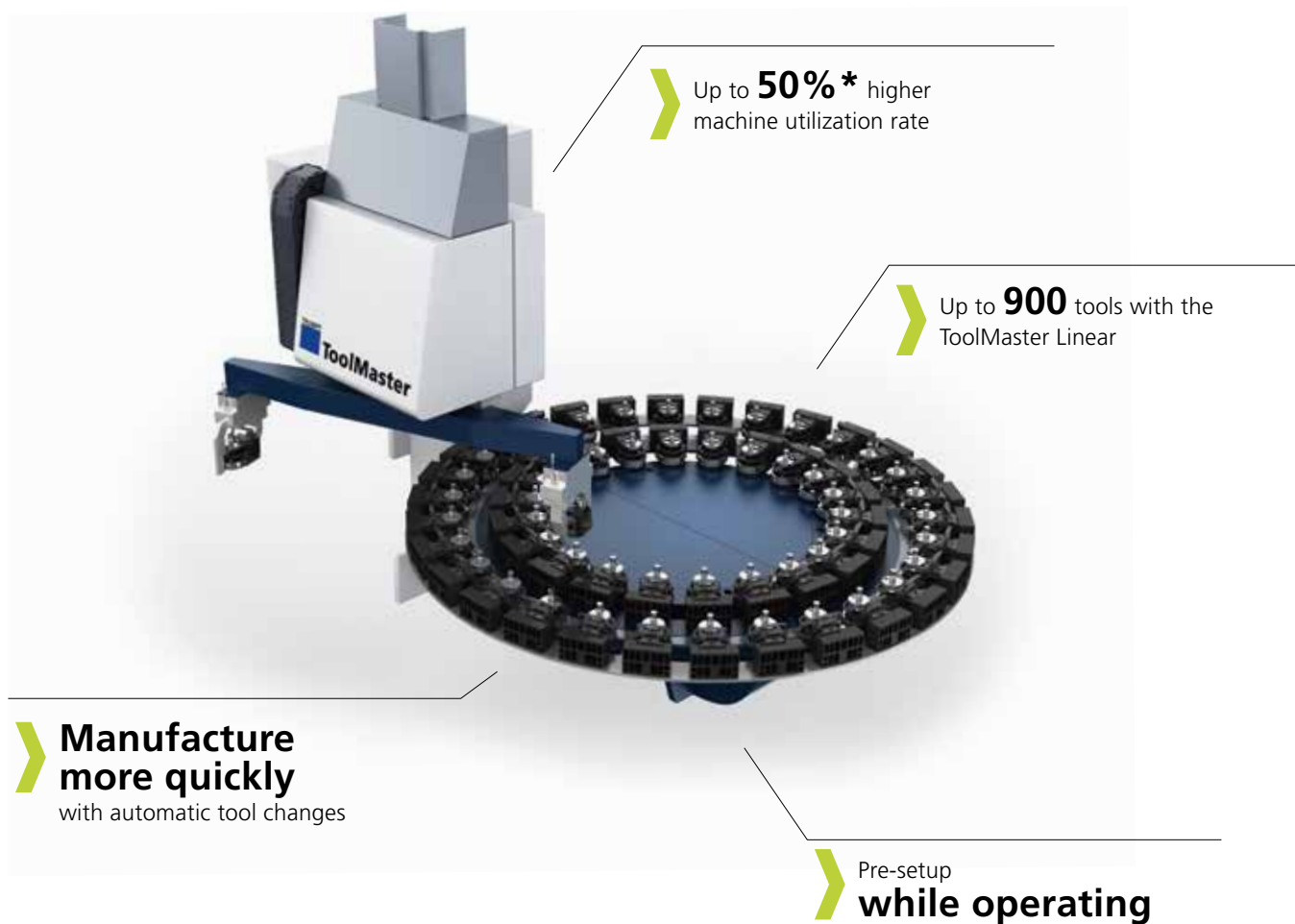

Using the right tool storage unit or changer boosts the productivity of your punching and punch laser machines. The classic ToolMaster has a carousel and puts the tools in position with the swivel arm. You can achieve maximum flexibility with a ToolMaster Linear. Its tool capacity can be gradually expanded up to 90 tool cartridges.

You no longer need to worry about how to cope with increasing variance and ever more complex parts. With the right tool system, you always have the appropriate tool at hand.



ToolMaster Linear

\* Previously two shifts, plus an additional unattended shift using a ToolMaster, ToolMaster Linear and an integrated tool changer.

“With the ToolMaster Linear, for the first time we have developed a system that can also be easily and flexibly retrofitted.”

**Thomas Conzelmann**, Product Manager for TruPunch/TruMatic



Integrated tool changer on the SheetMaster.



The TruPunch 5000, automated with a SheetMaster and ToolMaster Linear.



TruMatic 7000 connected to a TruStore 3030, with a SheetMaster, double cart on rails, SortMaster Pallet, SortMaster Box, GripMaster and ToolMaster.

Technical data					
Tool storage and changing systems		TruPunch 3000	TruPunch 5000	TruMatic 6000	TruMatic 7000
<b>ToolMaster</b>					
Number of locations		-	-	40/70	40/70
Setup parallel to production		-	-	□	□
<b>Tool changer integrated in SheetMaster</b>					
Number of stations		24 for medium format/ 40 for large format	-	34*/40	-
Setup parallel to production		□	-	□	-
<b>ToolMaster Linear</b>					
Number of stations	N	-	18/54/90	-	-
Setup parallel to production		-	-/■/■	-	-

■ Standard    □ Optional    N Retrofitting might be possible    - Not available

\* With bottom unload double cart.

Subject to change. Only specifications in our quote and order confirmation are binding.



“With a focus on intelligent software and sensor technology, we develop cells that master our customers’ complex bending processes smoothly and with high productivity.”

**Bernhard Fischereider**, Head of Development of TruBend

# Automated bending provides relief.

Automated bending with TruBend Cell increases your output and allows you to operate more profitably. You can run your production operations in multiple shifts with a minimum of personnel. The consistently high quality of your components cuts down on rework and rejects. Integrated solutions with sophisticated sensors and software, optimized material flows and state-of-the-art gripper technology deliver reliable processes and convincing results.

## LOADING + UNLOADING + SORTING

### **TruBend Cell 5000** \_\_\_\_\_ **46**

The productive universal bending cell

### **TruBend Cell 7000** \_\_\_\_\_ **48**

The innovative high-speed bending cell

The productive universal bending cell

# TruBend Cell 5000

Heavy parts of  
up to **220 lbs**

Large parts of up to  
**10 ft x 5 ft**



Utmost **part precision**  
with angle sensors

Flexibly **configurable**  
to meet your needs

**This flexible bending cell featuring the BendMaster, an integrated bending robot, is especially productive in manufacturing your individual parts range. Depending on the weight and size of the parts, you select the machine and BendMaster format appropriate for you.**

With its pivoted-jaw gripper and vacuum gripper, the BendMaster reliably takes parts through the bending process. With the automatic gripper change, the cell carries out the most diverse orders, one after the other, with ease. Aided by conveyor belts and pallet conveyors, you design the material flow of the TruBend Cell 5000 to meet your requirements.

“With the automatic bending cell, we have succeeded in killing two birds with one stone. We relieve our employees of heavy physical effort while at the same time becoming more profitable.”

**Dirk Matussek**, Matussek Metalltechnik GmbH (a sheet metal processor)

■ Read the full report at [www.mastersofsheetmetal.com/matussek](http://www.mastersofsheetmetal.com/matussek)



The pivoted-jaw gripper with transversing and rotary axes are highly productive in processing small parts.



The vacuum gripper for handling large parts.

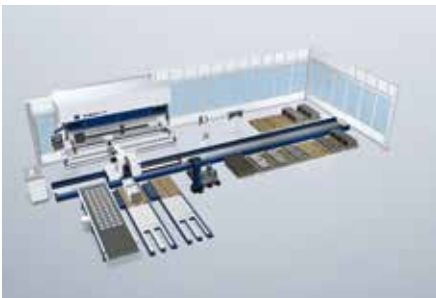

The TruBend 5170, BendMaster (60), with a 46 ft track length, conveyor belt, pallet conveyors, metal sheet removal station and gripper change console.

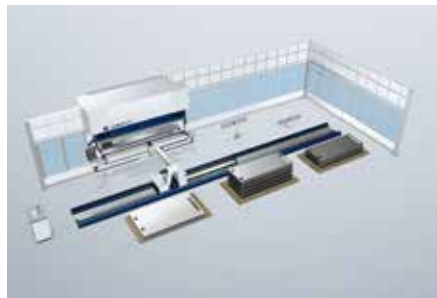

The TruBend 5230, BendMaster (150), with a 46 ft track length and gripper change console.



■ Experience the **TruBend Cell 5000 in action:**  
[www.trumpf.info/jwx5gf](http://www.trumpf.info/jwx5gf)

Technical data			
TruBend Cell 5000		TruBend Cell 5000 with BendMaster (60)	TruBend Cell 5000 with BendMaster (150)
TruBend Series 5000		From 5085 to 5320	From 5130 to 5320
Max. component size	in x in	80 x 40	120 x 60
Profile	in	Up to 100	Up to 160
Max. component weight	lbs	88	220
Max. carrying capacity	lbs	132	330
Min. sheet thickness	in	0.02	0.02
Track length	ft	20–46	20–52
Max. blank stack	in	28	28
Max. stack height for finished parts	in	39	47

Subject to change. Only specifications in our quote and order confirmation are binding.

2D LASERS

LASER TUBE CUTTING

PUNCHING + PUNCH LASER

BENDING

STORAGE

SOFTWARE

The innovative high-speed bending cell

# TruBend Cell 7000

**100%\***  
more output

Optimized  
**material flow**  
on 226 ft<sup>2</sup>



**Reliable processes**  
with intelligent sensor technology

User-friendly  
**offline programming**

**The TruBend Cell 7000 is the fastest system in the world for the automated bending of small parts. Two synchronized robots work in parallel to supply material and bend parts. This gives you the edge in high productivity with unbeatable low part costs.**

Fast individual components and perfectly coordinated processes make it possible to achieve a part throughput that is twice as high as with conventional bending cells. And, with the automatic tool changer, ToolMaster Bend, you can carry out work orders with exceptional flexibility – even for small batch sizes. Offline programming is efficient and reduces downtime. The system palette of the LoadMaster Bend can provide up to 24 different components.

\* Compared to manual bending; depends on part geometry.



“For me, this is a real innovation – the part supply, the flexibility of the system pallets and the LoadMaster. The cell is just great all around.”

**Manfred Wujesch**, Wincor Nixdorf Manufacturing GmbH  
 ■ Read the full report at [www.mastersofsheetmetal.com/wincor-nixdorf](http://www.mastersofsheetmetal.com/wincor-nixdorf)



Perfectly matched to one another:  
 The TruBend 7036 Cell Edition plus BendMaster.



ToolMaster Bend sets up tools completely automatically.



TruBend 7036 Cell Edition, BendMaster (15), LoadMaster Bend, ToolMaster Bend and conveyor system.



■ Experience the **TruBend Cell 7000 in action:**  
[www.trumpf.info/jy4er9](http://www.trumpf.info/jy4er9)

Technical data		
TruBend Cell 7000		TruBend Cell 7000 with BendMaster (15)
Max. component size	in x in	20 x 15
Max. sheet thickness	in	0.3
Max. component weight	lbs	6.5
Max. carrying capacity	lbs	33
Press force	t	40
Working speed	in/s	Up to 2 in/s
Dimensions	in x in	217 x 152

Subject to change. Only specifications in our quote and order confirmation are binding.

2D LASERS

LASER TUBE CUTTING

PUNCHING + PUNCH LASER

BENDING

STORAGE

SOFTWARE

“Whether a novice or an advanced user, we offer you the full range of solutions: from compact to scale storage systems.”

**Patrick Bauer**, Product Marketing for Automation and Processes

# Store more efficiently.

With TRUMPF storage and logistics systems, you have a modular kit of intelligent storage solutions. The right storage system improves the material flow and ensures smooth production processes. You better utilize your machines and save space, time and money.

## STORAGE + LOGISTICS SYSTEMS

### **TruStore Series 1000** \_\_\_\_\_ **52**

Practical compact storage system

### **TruStore Series 3000** \_\_\_\_\_ **54**

The most flexible storage system

### **Large-scale storage systems** \_\_\_\_\_ **56**

Highest efficiency for your manufacturing process

### **Logistics concepts** \_\_\_\_\_ **58**

Automation concepts tailored to your needs

Practical compact store

# TruStore Series 1000

**33** metric ton storage capacity in large format



Up to **50%\*** higher machine utilization rate

**Expandable**  
to TruStore Series 3000

**The reliable and economical compact store facilitates material handling and offers you the perfect entry into TRUMPF storage technology.**

The TruStore Series 1000 seamlessly complements your automated sheet metal production and makes you even more efficient. The store is served by the LiftMaster Store or LiftMaster Store Linear. With a pallet picker crane, you can upgrade your TruStore Series 1000 to a TruStore Series 3000.

\* Two shifts during the day, with an additional unattended shift at night.

“The compact storage system creates more free space for our TruStore production facility. We achieve shorter throughput times and greater output.”

Radek Tybl, Plant Manager of TRUMPF Liberec

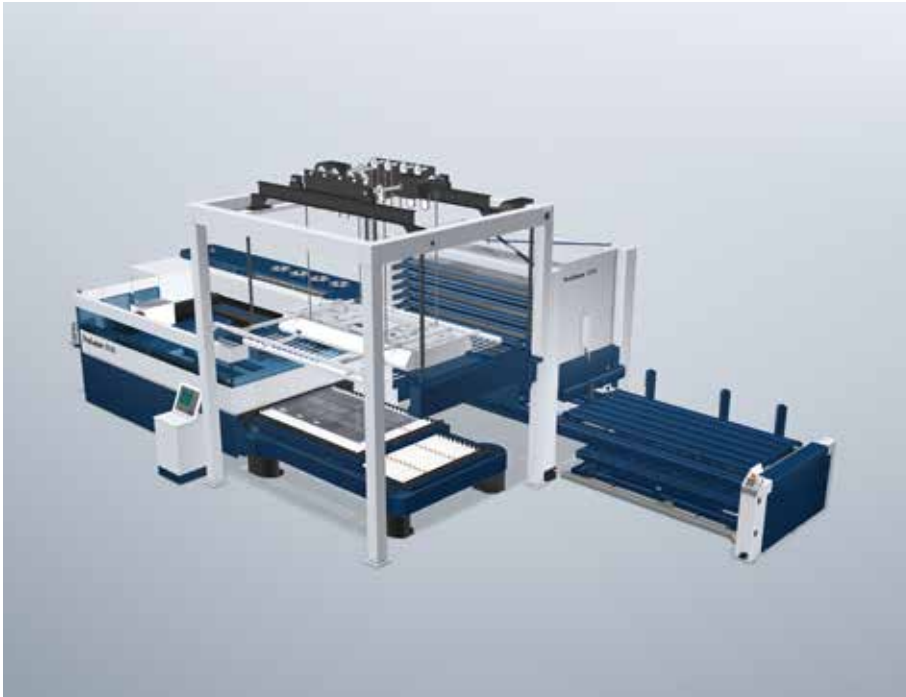

TruLaser with TruStore 1030 and LiftMaster Store.



■ Experience the **TruStore in action:**  
[www.trumpf.info/urnl28](http://www.trumpf.info/urnl28)

Technical data			
TruStore		Large format	Max format
		1030	1040
<b>Direct connection to</b>		LiftMaster Store	
Max. sheet format	in x in	120 x 60	160 x 80
Max. system height	in	153	153
Max. loading height per pallet	in	3.5/6.5	3.5/6.5
Max. weight per pallet	lbs	6600	11000
Max. pallet quantity*		10	7
Max. storage capacity*	t	30	35
Typical equipment			
Cart systems	N	<input type="checkbox"/>	<input type="checkbox"/>
Auxiliary pallet mode	N	<input type="checkbox"/>	<input type="checkbox"/>

Optional

N Retrofitting might be possible

\* Loading height 3.5 in.

Subject to change. Only specifications in our quote and order confirmation are binding.

The most flexible store

# TruStore Series 3000

Up to **100%\*** higher machine utilization rate

Up to **222** metric tons of storage capacity in large format



**85%** reduction in space requirements

Flexible at all times  
**Reconfigurable and expandable**

**The dynamic compact storage system grows with your requirements, needs less space and can be expanded up to the completely automatic system.**

In its standard configuration, the TruStore Series 3000 comes with a storage tower and pallet picker crane. You select the height of your storage system from fifteen possible levels, of which the storage compartments are adjustable to 3.5 or 6.5 inches. The store can be easily connected to your TRUMPF 2D laser cutting system, punching or punch laser machine. Because of its modular design, extensions can be added on at any time.

\* Two shifts during the day, additional unattended shifts at night and continuously on weekends.

“Major added value comes from the modular structure, thanks to which this store – probably the most flexible one around – can be easily expanded at any time.”

**Pavel Mach**, Head of Development of TruStore

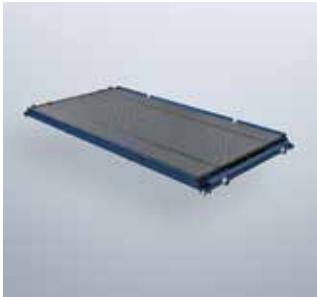

Space-saving storage of auxiliary pallets with storage cartridges.



PartMaster integration; the TruStore with TruLaser 3030 fiber.



The TruLaser 3030 with LiftMaster Compact, directly connected to the TruStore 3030.



The TruMatic 7000 with SheetMaster and double cart, indirectly connected to the TruStore 3030.



■ Experience the **TruStore in action:**  
[www.trumpf.info/urnl28](http://www.trumpf.info/urnl28)

Technical data			
TruStore		Large format	Max format
		3030	3040
Direct connection to		LiftMaster Compact/LiftMaster Store/LiftMaster Store Linear	
Indirect connection (via cart systems) to		SheetMaster/LoadMaster/ LiftMaster/LiftMaster Sort/ LiftMaster Linear/LiftMaster Linear Basic*	
Max. sheet format	in	120 x 60	160 x 80
Max. system height	in	325	330
Loading height per pallet	in	3.5/6.5	3.5/6.5
Max. weight per pallet	lbs	6600	11000
Max. pallet quantity**		74	47
Max. storage capacity**	t	222	235
Typical equipment			
Pallet picker crane		■	■
Weighing device	N	□	-
Cart systems	N	□	□
PartMaster integration	N	□	-
Auxiliary pallet mode	N	□	□
Multi-machine connection	N	□	□

■ Standard □ Optional N Retrofitting might be possible – Not available

\* LiftMaster Linear Basic only with large format 3030. \*\* At max. system height, two-tower version, loading height 3.5 in front machine connection. Indirect and longitudinal loading/unloading cart in the same tower.

Subject to change. Only specifications in our quote and order confirmation are binding.

The utmost efficiency for your manufacturing operations

# Large-scale storage systems

Non-stop productivity  
**24** hours a day,  
**7** days a week

**Low**  
 service and maintenance costs\*

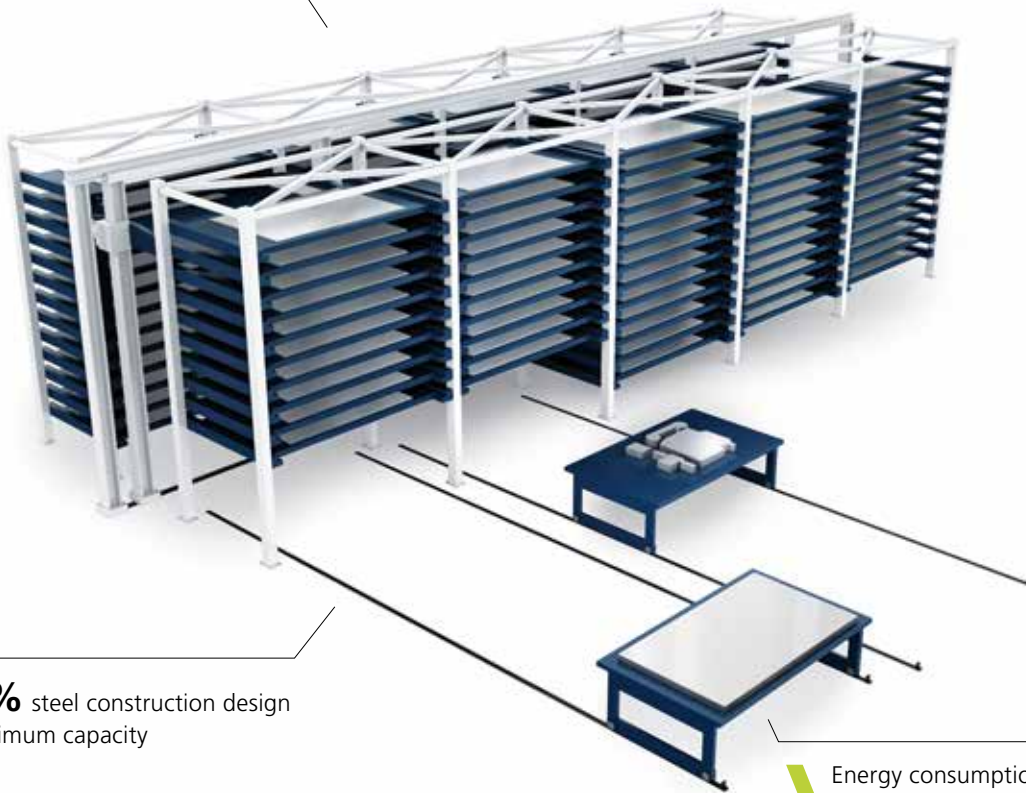

**100%** steel construction design  
 for maximum capacity

Energy consumption cut by up to  
**25%\*** through recovery

**STOPA large-scale storage systems are more than just material stores – they take on the comprehensive tasks of a logistics center for your production setup.**

With its modular design, your STOPA large-scale storage system is completely flexible in terms of length, width, height, and sheet format. Even in the most confined area, it offers plenty of space for unprocessed sheets, finished parts, sheet skeletons and tube profiles. A practical pallet picker crane lets you maneuver storage pallets.

\* Compared to conventional large-scale storage systems.



“The competition in sheet metal processing is enormous. With the STOPA high storage bay system, we were able to significantly improve the part quality and our productivity through automated material management. In this way, we try to increase the efficiency – for us and for our customers.”

**Kwak Yun Chon**, Laser Center, Siheung

■ Read the full report at [www.mastersofsheetmetal.com/lasercenter](http://www.mastersofsheetmetal.com/lasercenter)



Smooth material flow in a fully automated system.



■ Experience the **large-scale storage systems in action**:  
[www.trumpf.info/8vd2an](http://www.trumpf.info/8vd2an)

Technical data				
STOPA large-scale storage systems		Sheet metal*		Tube*
		Large format	Max format	LG-U
Direct connection to		LiftMaster Compact/ LiftMaster Store/LiftMaster Store Linear		–
Indirect connection (via cart systems) to		SheetMaster/LoadMaster/ LiftMaster/LiftMaster Sort/ LiftMaster Linear/LiftMaster Linear Basic**		LoadMaster Tube
Max. sheet format	in	120 x 60	160 x 80	–
Storage system length	in	–		120–2400
Max. system height	ft	52.5		85
Loading height per pallet	in	3.5/11	3.5/12	–
Max. weight per pallet/cartridge	t	3	5	5
Pallet quantity		> 100		80–500
Storage capacity	t	> 300	> 500	400–2500
Typical equipment				
Pallet picker crane		■	■	■
Order picking tower		□	–	–
Building-supporting structure		□	□	□
Weighing device		□	□	□
Cart systems	N	□	□	□
Quick pallet changer/tandem stations	N	□	□	–
Auxiliary pallet mode	N	□	□	–
Multi-machine connection	N	□	□	□

■ Standard □ Optional N Retrofitting might be possible – Not available

\* Additional formats upon request. \*\* LiftMaster Linear Basic with large format only.

Subject to change. Only specifications in our quote and order confirmation are binding.

Automation concepts perfectly tailored to your needs

# Logistics concepts

With customized large storage systems we offer not only a machine or storage system, but a comprehensive production concept. With this approach, the entire production process is in focus: from bringing the raw sheet into the process right through to the bent and painted finished part. An optimal material flow solution is worked out together with the customer.



## Small to Medium Autonomous Cell

One or two machines are connected to automated devices for loading, unloading, and potentially sorting. A storage tower unit supplies the machine with raw material and can later be used to store cut sheets. The system functions as an autonomous production cell.



## Customized Material Storage System

Machines are connected to a large storage system which supplies each machine with raw material. The material flows only in one direction - from storage unit to additional processes. Typically, this concept is highly efficient if the storage unit is installed close to a wall, and the machines are connected to one side of the unit.

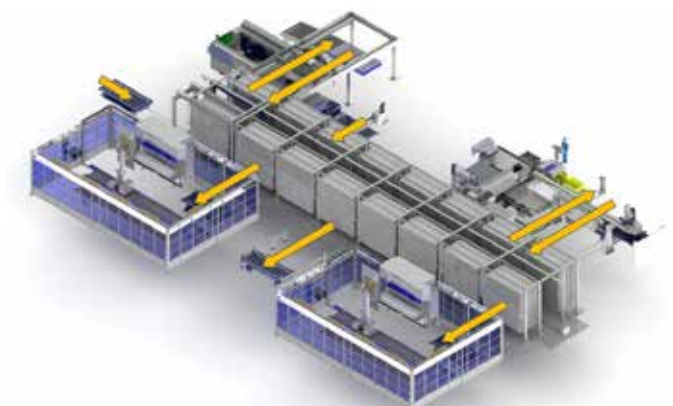

## Customized Full Logistics Center

Machines are connected to a large storage system that handles raw material and semi-finished goods automatically between various processing steps. The storage unit serves as a logistics system and is usually located in the center of production. Machines are typically connected to both sides, allowing for material flow in various directions, and a buffer function for production purposes is possible. The key to this structure is overall process control and monitoring.

“Material storage systems, both small and large, have a significant impact on intralogistics and overall efficiency in a sheet metal shop. It is important to understand all benefits in order to tailor the right system for each customer.”

Tobias Reuther, Manager Automation Group

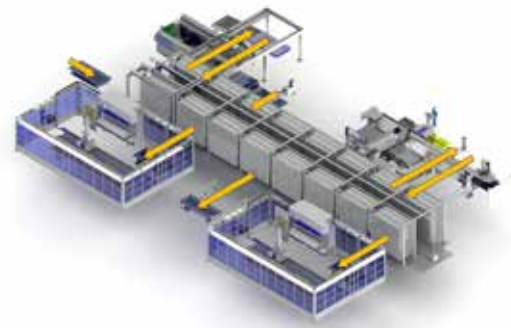

Customized Large Storage System Comparison		
Customized Raw Material Storage System		Customized Complete Logistics Center
One direction (away from storage system)	<b>Material Flow</b>	Bi-directional
Raw material storage system	<b>Storage Serves as</b>	Raw material storage system Semi-finished goods buffer Means of transport
Along a wall	<b>Located</b>	In the center of the hall
Lower Investment	<b>Economic Effects</b>	Higher investment, but cost-advantages in subsequent processes (quality, required forklifts, etc.)
Raw material	<b>Buffering</b>	Raw material Semi-finished goods
Commissioning by the operator immediately after punching or laser processing	<b>Manual Material Handling</b>	Manual material handling minimized
Well suited for quick lead times	<b>Lead Times</b>	Minimum lead times are not pursued without limitation
Single batch flow	<b>Production Principle</b>	Pull principle, more work in progress (single batch flow)
Quick lead times Ideal material flow Lower investment	<b>Main Advantages</b>	Storage and logistics service Process linking Higher flexibility

# Manage your overall production with ease.

From your customer's inquiry to the dispatch of the finished job: With the modularly structured TruTops software, you can control your entire production process. You also benefit from the function for managing your customers' orders and purchasing processes. A quick look online lets you see the status of your production and what stage your shop orders are at, as a result of a direct link with the machine control system. TruTops can be flexibly integrated into your existing software system.



TruTops Fab and the Mobile Control App: Remote machine control

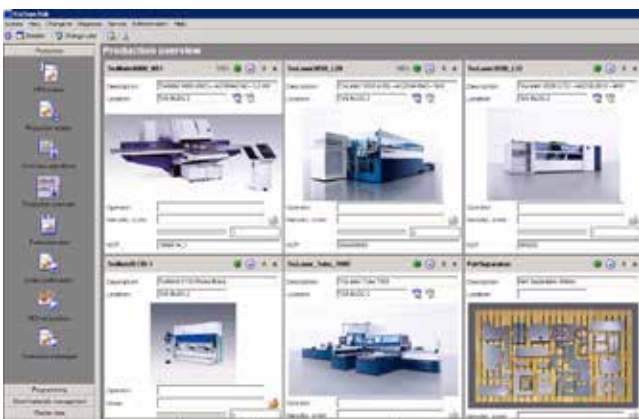

TruTops Fab: machine status monitoring

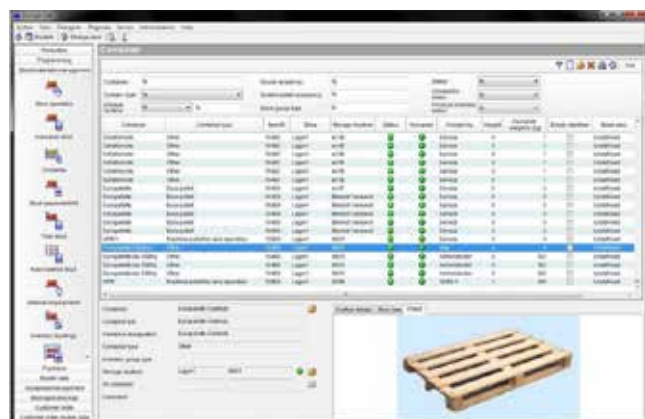

TruTops Fab: complete order and inventory management

**PROCESS**

**Customer inquiry**



**Preparatory work**



**Production**



**Internal logistics**



**Shipping**



**TASK**

Calculate quote

Create quote

Record customer order

Create internal work order

Import/design part

Program order

Assign job to machine

Monitor machine data

Visualize machine status

Take care of subassembly handling

Notify in case of malfunction

Notify upon completion

Control automated storage

Manage manual storage

Order material

Generate delivery note

Issue invoice

**SOLUTION**

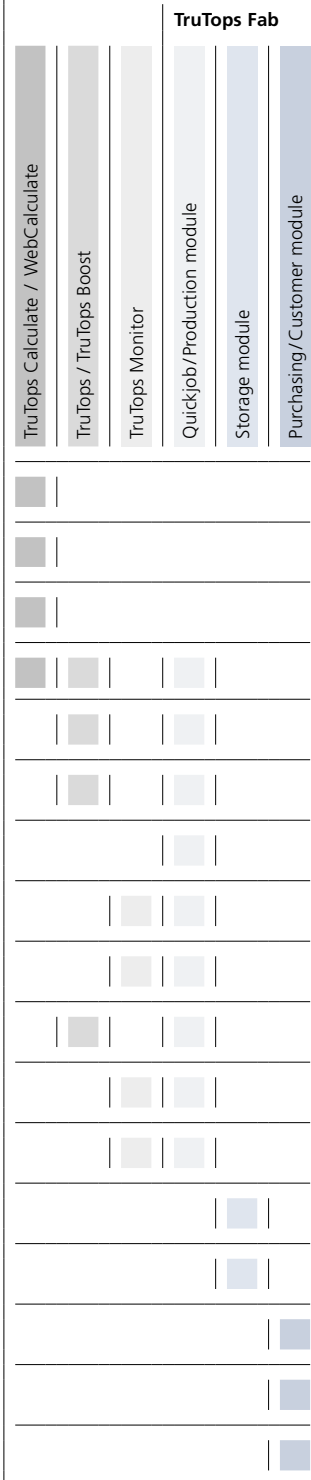

TRUMPF is certified to ISO 9001:2008  
(find out more at [www.us.trumpf.com/en/about-trumpf/quality](http://www.us.trumpf.com/en/about-trumpf/quality))

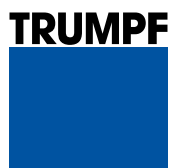

TRUMPF Inc.  
[www.us.trumpf.com](http://www.us.trumpf.com)